



ARVOR-PROVOR Technical Workshop



IFREMER – Brest
January 2020

nke instrumentation

- ❏ Located in Hennebont, Brittany, France
- ❏ Specialized in oceanographic instrumentation since 1993
- ❏ 35 employees
- ❏ Float activity since beginning 90's in Martec, Kannad companies, and now in nke since 2009
- ❏ A long and constant partnership with IFREMER and now with LOV (CNRS) and Sorbonne University
- ❏ More than 2000 floats produced



- ❏ With courtesy from LOV, IFREMER and PML for “at sea” photos

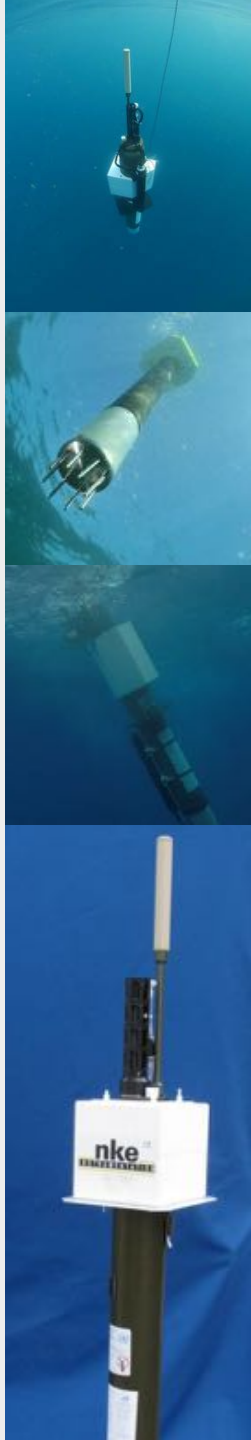

nke facilities

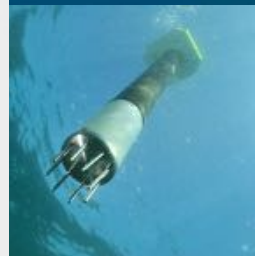
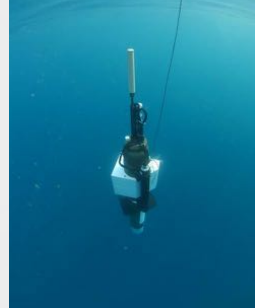

nke instrumentation

- ❏ Designer, manufacturer and seller of **instruments and systems for water measurements and environmental monitoring**
- ❏ **Open Ocean, deep sea, coastal areas, rivers, lakes**
- ❏ Involved in **national and international research projects**

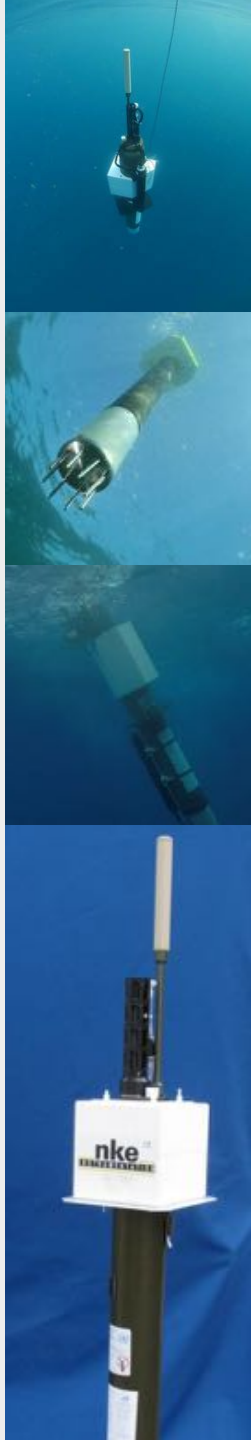

Some dates,

- ❏ **1993**: marketing of the first autonomous data logger
- ❏ **2001**: creation of the instrumentation department
- ❏ **2005**: change in company name, Micrel becomes **nke**
- ❏ **2009**: integration of Floats & Drifters activity from Kannad company
- ❏ **2010**: new metrology laboratory
- ❏ **2012**: **nke** INSTRUMENTATION becomes an independent company
- ❏ **2018 & 2019** : 1st ARGO float manufacturer (deployed float per year)



Our team

- ❏ **Manager:** Jean-Claude Le Bleis, Yves Dégrés
- ❏ **Marketing and Sales department** (7 persons)
- ❏ **Administrative staff** (Purchasing, logistics) (5 persons)
- ❏ **Engineering:** electronic, mechanical, and software design (12 persons)
- ❏ **Manufacturing and metrology department** (12 persons)
- ❏ **Support and after sales service** (2 persons)

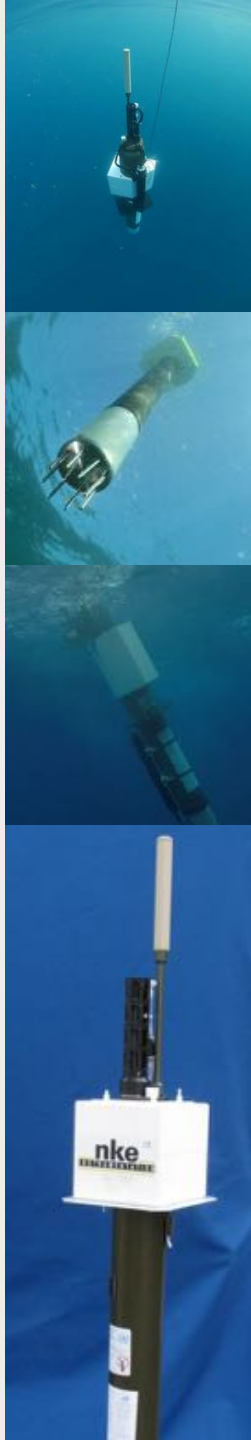

Our team



nke
INSTRUMENTATION

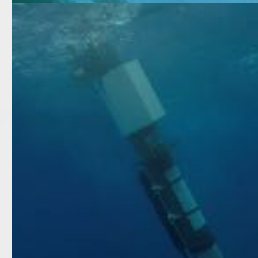
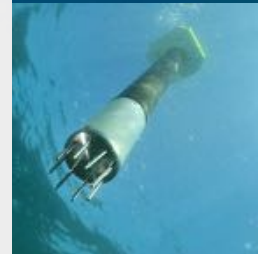
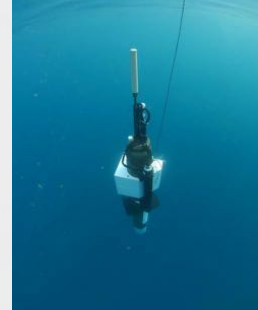

Our facilities : calibration laboratory



nke facilities : production area



Manufacture Area
approx : 150 m² dedicated to instrumentation,
extension possible depending on projects and
activity



Storage Area
approx : 550 m³

Up to 400 floats per year capability



Range of Products



Multiparameter probes

Autonomous multiparameter probes with radio, inductive or Wifi communication



Automated networks

Autonomous measurement networks for water and environmental monitoring



Floats and drifters

Argo profiling floats, SVP-B drifters



Customer support for Profiling floats

Who is your contact ?

Commercial team : 2 dedicated persons for Profiling floats

Purchase order

Quote request (formal or budget)

Preliminary discussion for project proposal (Technical, ...)

Others questions ...

=> nlebris@nke.fr & jsagot@nke.fr or

info.instrumentation@nke.fr -> all commercial team (NLB, JS, YD + 3 persons)

After sales team : 4 persons

Administrative (2) : N. Le Bris (nlebris@nke.fr) , J. Sagot (jsagot@nke.fr)

Technical support (3) : D. Nogr  (dnogre@nke.fr) for Core, Deep & CTS4,
C. Schaeffer (cschaeffer@nke.fr) for CTS5 , J. Sagot

Support.float@nke.fr to adress these 4 persons (**recommended**)

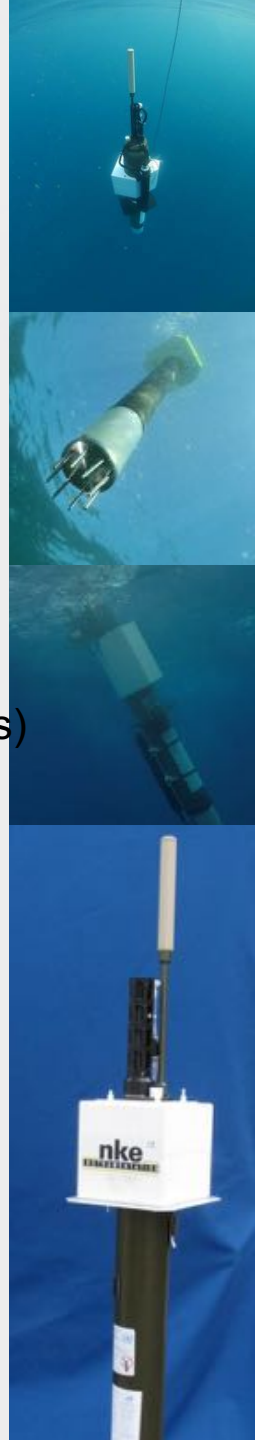

ARGO actual and future situation

ARGO is now a mature program since more 25 years with a global array of 4000 floats operating at sea.

New goals of ARGO program are to increase marginals seas and polar areas deployments, and explore DEEP Ocean with DEEP-ARGO floats (4000 and 6000m floats) and also extension of BGC-ARGO program

For all these objectives, nke is able to provide some technological solutions and products, through its large range of float's type

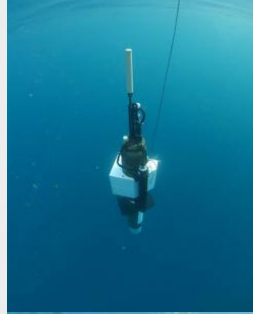

ARGO actual and future situation

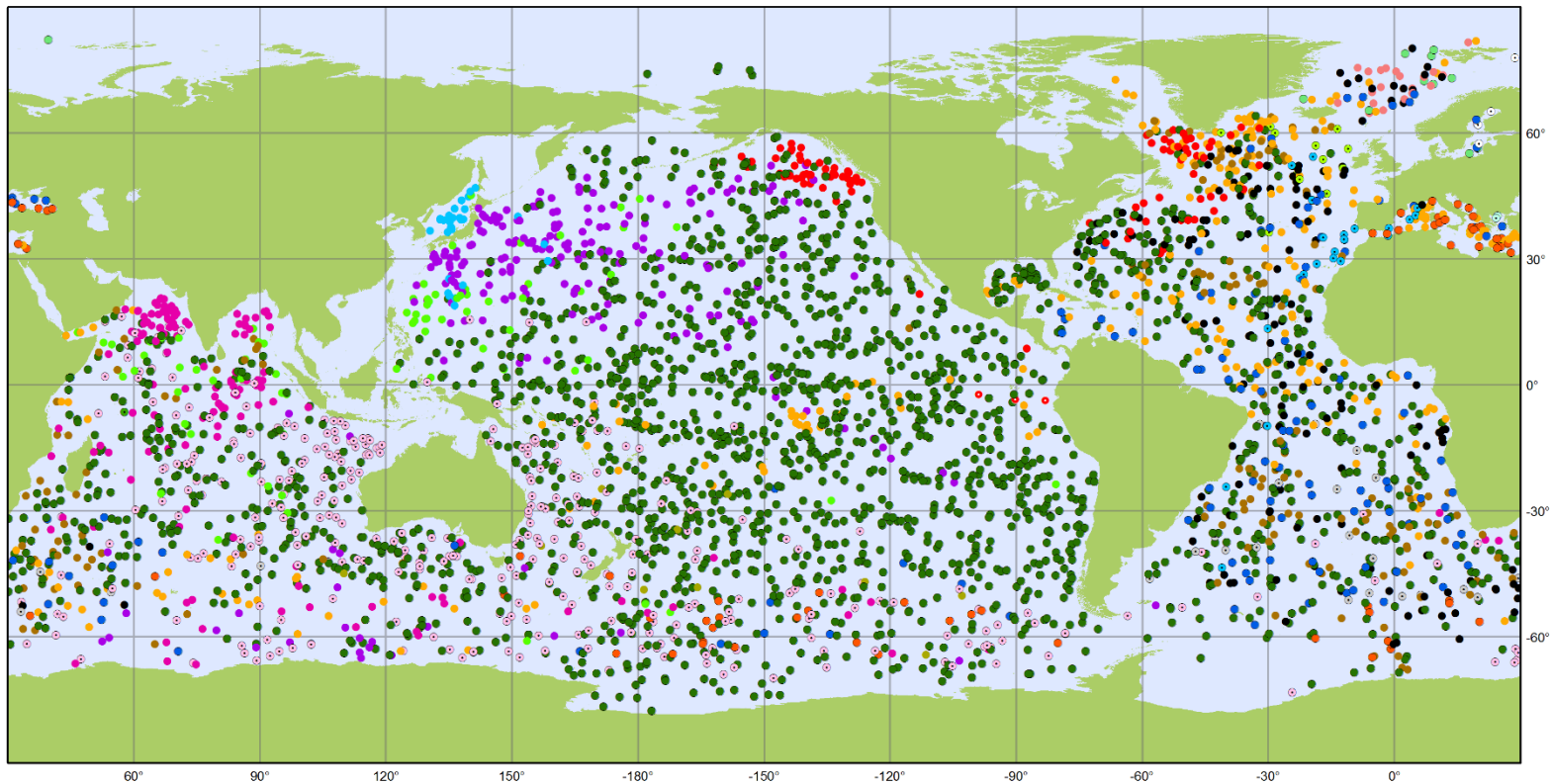

Argo

National contributions - 3850 Operational Floats
 Latest location of operational floats (data distributed within the last 30 days)

October 2019



- | | | | | | |
|-------------------|-----------------|----------------|--------------------|---------------------------|--------------|
| ○ AUSTRALIA (336) | ○ FINLAND (5) | ● INDIA (139) | ● KENYA (1) | ● NORWAY (22) | ● SPAIN (24) |
| ● CANADA (93) | ● FRANCE (279) | ● IRELAND (12) | ● MEXICO (1) | ● PERU (3) | ● UK (159) |
| ● CHINA (75) | ● GERMANY (155) | ● ITALY (69) | ○ NETHERLANDS (24) | ● POLAND (11) | ● USA (2061) |
| ● EUROPE (124) | ○ GREECE (2) | ● JAPAN (214) | ● NEW ZEALAND (10) | ● KOREA, REPUBLIC OF (31) | |

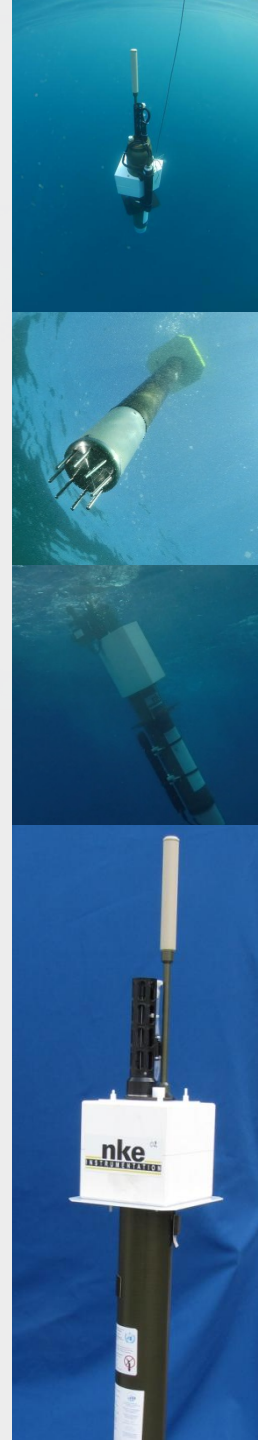

ARGO deployments per year and per manufacturer





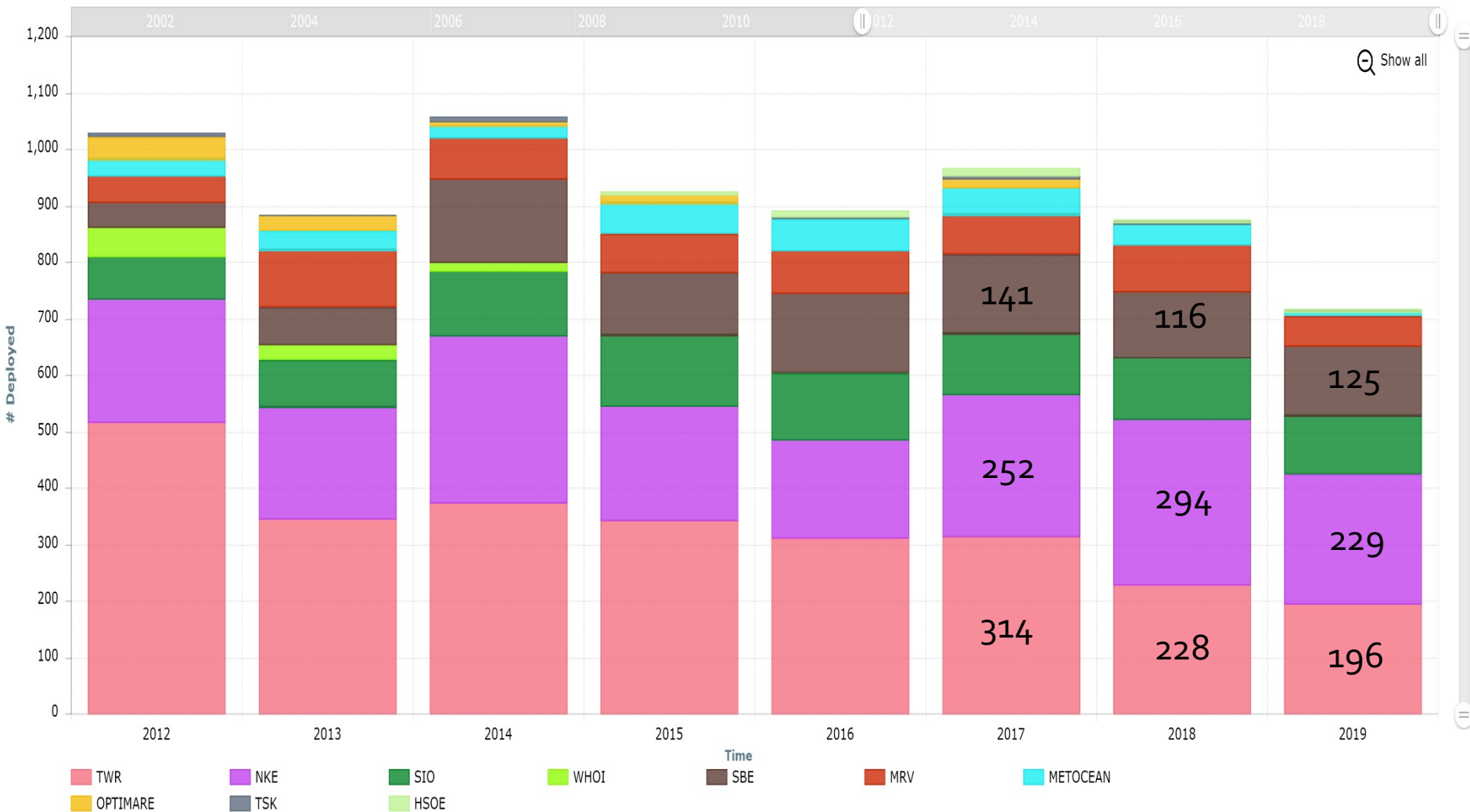

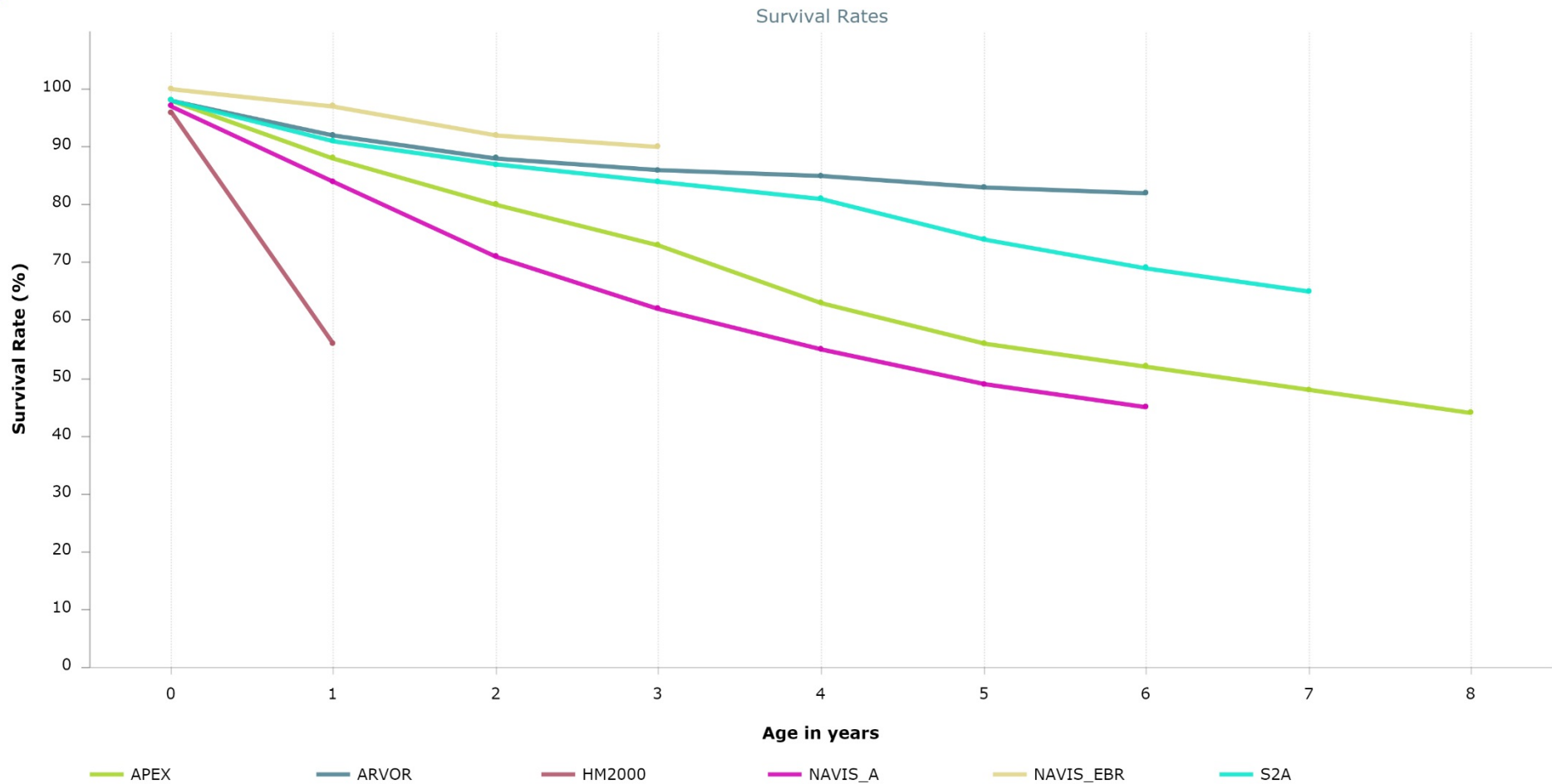
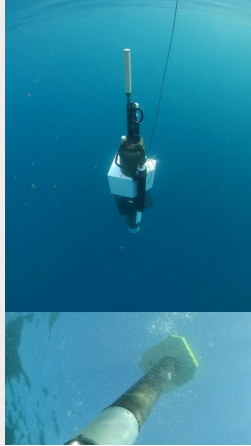

Deployments Timeline



ARGO survival rate per model



Range of Floats

Type	Nke model	Comments
ARGO TS, 2000 m, Argos	Arvor-L, Arvor Provor CTS3	Argos 2 200 CTD points max per profile 
ARGO TS, 2000 m, Iridium	Arvor-I Provor-I	Iridium SBD Up to 2000 CTD pts in a profile Ice detection function 
ARGO TS, 2000 m, Iridium	Arvor-I -RBR NEW	Iridium SBD Up to 2000 CTD pts in a profile Ice detection function 
ARGO TS, DO, 2000 m Argos & Iridium	Provor-DO Arvor-DO Provor-DO I Arvor-DO-I	CTD & DO, Argos2 CTD & DO, Iridium SBD, 2000 pts, Ice detection 
ARGO TS, DO 4000 m	Deep ARVOR	CTD & DO, Iridium SBD, 4000 pts, Ice detection 
BGC, TS, 2000 m	Provor CTS 4 Provor CTS5 NEW	BGC sensors : D O, Radiometer, fluorometers, ^{biogeochemical} transmissometer, nutrients , NOSS, pH Iridium rudics, 0.2 dBar resolution, Ice detection UVP6-LP on progress (CTS5 only) 
TS, DO, 400 m TS, Tu, Fl, DO, 400 m	Arvor C Arvor-Cm	Coastal applications (CTD & DO), Iridium SBD metric resolution
ARGO TS, 2000m, Beidou	PROVOR Beidou NEW	Beidou transmission, CTD or Acoustic+TD
Acoustic spectrum, 1000 m	Provor AC, AC2	Hydrophone, data processing, Iridium transmission

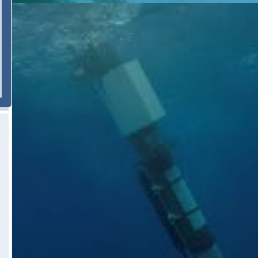
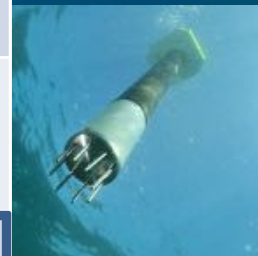
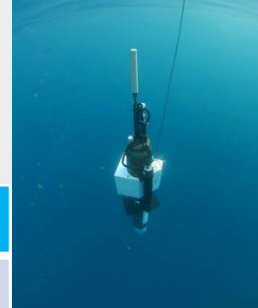

Core-ARGO floats

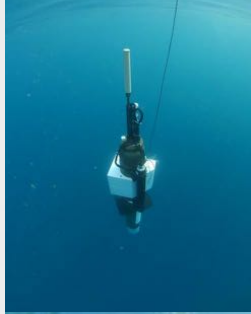

ARVOR & PROVOR



	PROVOR CTS3	ARVOR
CTD Sensor	SBE 41 CP Sea bird CTD with pump	
Engine	high pressure hydraulic pump	
Weight	34 Kg → 50 Kg	20 Kg
Tx mode	Argos 2 Iridium SBD & rudics	Argos 2 & 3 Iridium (SBD)
Dimensi ons	Φ 17 cm L 170 cm	Φ 11 cm L 120 cm
	dedicated for multi-sensors embedded with good payload capacity	CTD optimized float for Argo application

nke
INSTRUMENTATION

**Radio link BT for user
parametric setting**

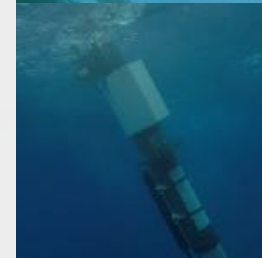
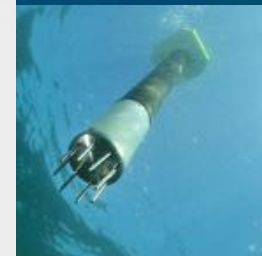
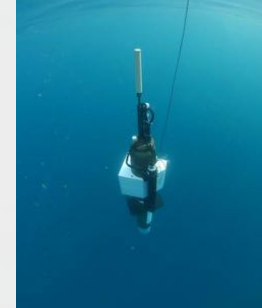

ARVOR & ARVOR-I

ARVOR dedicated to core-ARGO program

- 20 Kg
- Able to operate between fresh water to 1038. Without preballasting
- Up to 250 cycles @10 days
- 3 typical zones (0-10m, 10-200m, 200-2000m)
- Up to 200 CTD points per profile
- Time at surface : 6-8 hours (Argos 2)

ARVOR-I specific features

- Up to 300 cycles @10 days, 100 pts, 2000 m.
- Short-Burst-Data (SBD) with 300 bytes messages.
- GPS receiver integrated
- All parameters can be modified after deployment (2 ways capability with SBD telecommand send by email)
- Time at surface : < 10 mins

nke
INSTRUMENTATION

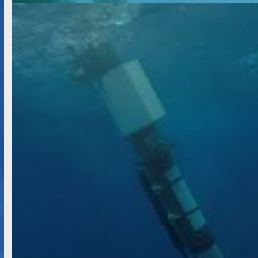
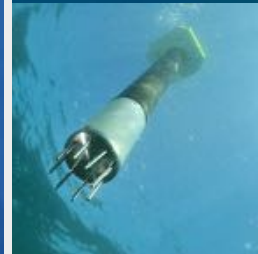
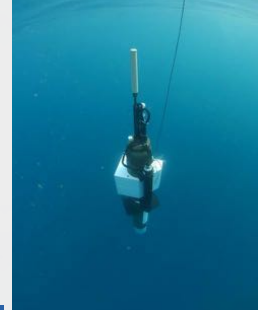

PROVOR CTS3.1

particular technical features

- "PROVOR_II" in Jcommops database
 - Oil volume 3 liters
 - 200 cc to move from 2000 meters up to near surface
 - Buoyancy system
- PROVOR is able to operate from fresh to dense sea water (1000 to 1038) without user ballasting => "Self-ballasted float"
Able also to be deployed in area with large density front.
- Easy additional sensors integration
- by using additional buoyancy
- increased embedded battery, +66 % 100 Ah for sensors
- oxygen optode directly mounted on upper end cap
 - Same improvements than Arvor
 - deployment procedure : simplification and sturdiness

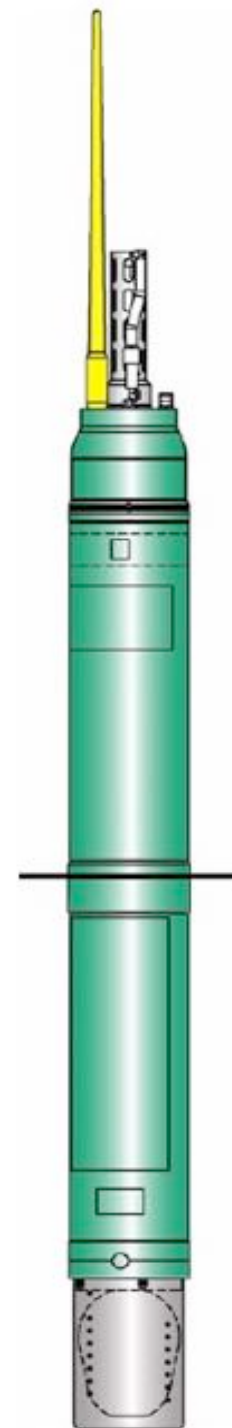

Core-ARGO floats with dissolved oxygen measurements

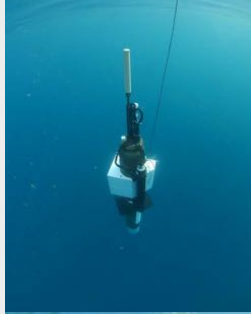

DO In Air Measurements



Elevation of the DO sensor to obtain a calibration in air when surfacing : required by ARGO DO community

Mounted on all ARVOR, DEEP-ARVOR & PROVOR with optode sensor

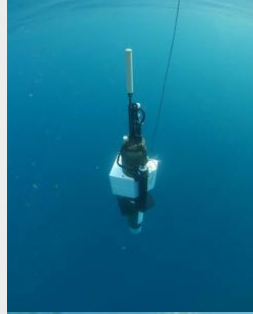

Core-ARGO floats Recent Evolution

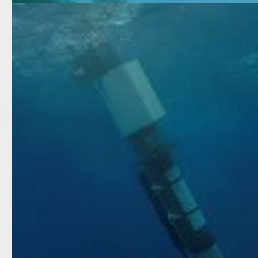
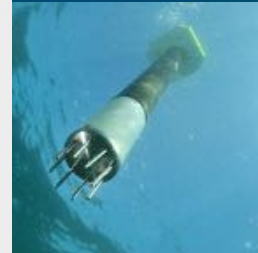
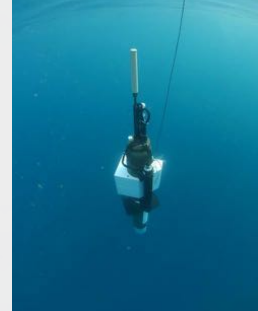

Firmware improvements on all nke floats

For both reliability and new functions

- ❏ Buzzer for deployment authorization (now Deep in addition to Core)
- ❏ New sampling zone in ascent after grounding (Deep)
- ❏ Buoyancy reduction optimization (less time at surface)
- ❏ Grounding Algorithm optimization
- ❏ High resolution measurement on bottom (Deep)
- ❏ Various improvements
 - ❏ Automatic mission start if armed mode is ON (Useful for non expert users and bad deployment sequence)
 - ❏ Different padding for empty packet in a message (not decoded as empty tech packet)
 - ❏ Self-test after armed mode command to check that float is ready for future deployment (focus during last preparation actions)
 - ❏ Synchronization of alternated profile and in-air measurement (if not required at each profile)

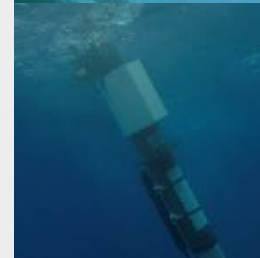
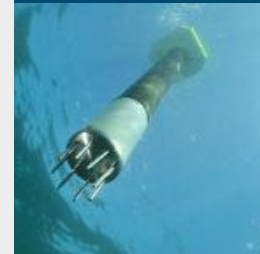
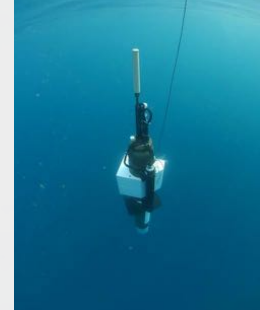

RBR CTD on ARVOR-I float



AST recommendation : Pilot Project & 100 floats with RBR CTD deployed per year

E-ARISE Project *



Two main goals for project

Sustain of global Argo network

Extension to Deep Ocean and BGC application

In partnership with IFREMER and RBR, RBR CTD will be integrated on ARVOR-I float to offer at the end of 2nd quarter 2020 an industrial float to community

Work has now started and delivery of 2 prototypes is scheduled for beginning of 2020

* This project has received fundings from the European Union's Horizon 2020 research and innovation programme under grant agreement n° 824131



Horizon 2020
European Union Funding
for Research & Innovation

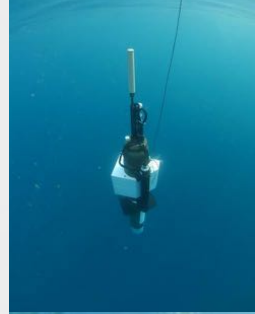

RBR CTD on ARVOR-I float

Same features than standard ARVOR-I

Main features of RBR CTD

Specifications

Physical

Power:	80 μ W sleep, 45mW sampling
Storage:	~120M readings
Communication:	UART, RS-232, USB-CDC
Energy/sample:	<18mJ
Energy/profile:	~400J (2000dbar sampling)
Sampling speeds:	Up to 8Hz
Materials:	OSP and titanium
Input voltage:	4.5V-30V

Conductivity

Range:	0 – 85mS/cm
Initial accuracy:	\pm 0.003mS/cm
Resolution:	0.001mS/cm
Typical stability:	0.010mS/cm per year

Temperature

Range:	-5°C to 35°C
Initial accuracy:	\pm 0.02°C
Resolution:	0.00005°C
Typical stability:	0.002°C per year
Time constant:	~700ms

➤ Theoretically : 100 cycles more than for pumped CTD floats !

Depth

Range:	2000 / 4000 / 6000dbar
Initial accuracy:	\pm 0.05% FS
Resolution:	0.001% FS
Typical stability:	0.1% FS per year
Time constant:	<0.01s

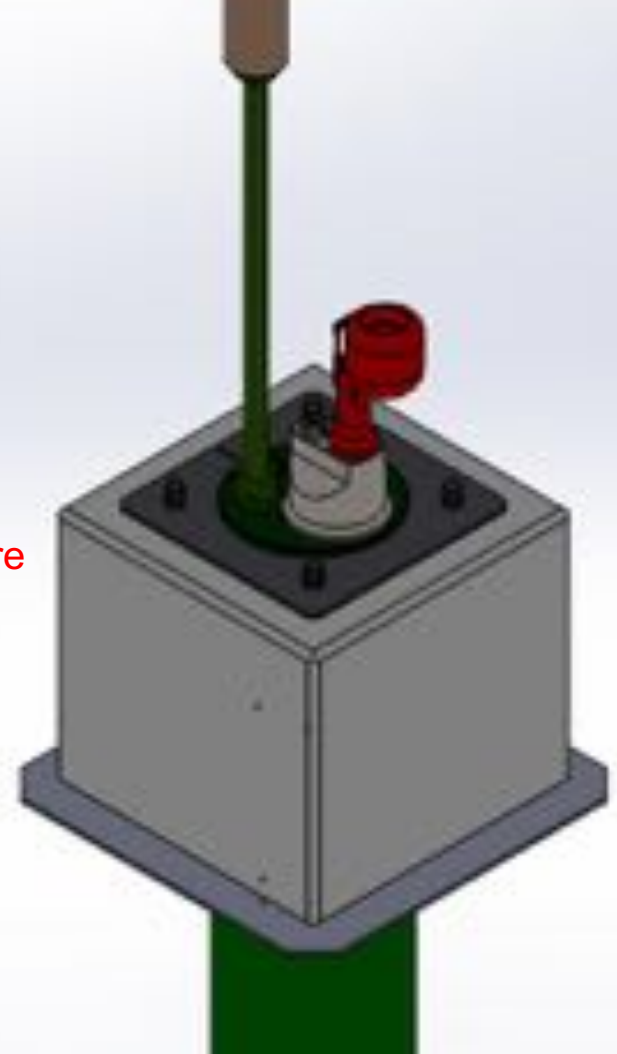

nke
RUMENTATION



DEEP-ARGO floats



DEEP ARVOR

- 4000 meters
- Up to 150 profiles @4000 dbar (Continuous pumping)
- Up to 200 profiles @4000 dbar (spot-sampling mode)
- SBE 41 CTD and optode 4330
- Fully programmable, alternate profile
- Up to 4000 points/profile
- Iridium SBD and GPS
- 26 Kg
- Lithium battery
- Diameter 14 cm
- total length 216 cm

Based on Arvor components (electronic board), increased capacity pump, matched CTD

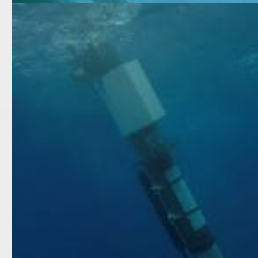
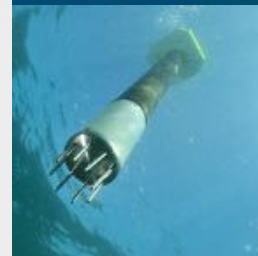
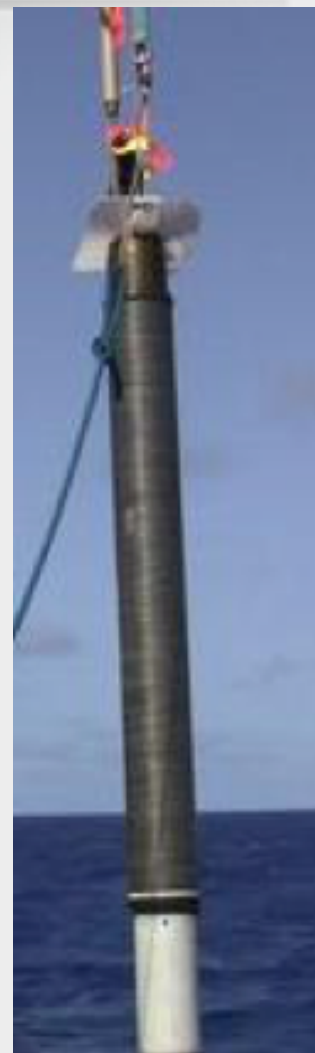





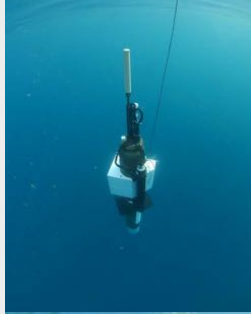

Developed by Serge Le Reste, Vincent Dutreuil, Coralie Trautman, Tanguy Bescond, Xavier André

© Ifremer/Sébastien Prigent

BGC-ARGO floats



Range of Floats

Type	Nke model	Comments
ARGO TS, 2000 m, Argos	Arvor-L, Arvor Provor CTS3	Argos 2 200 CTD points max per profile 
ARGO TS, 2000 m, Iridium	Arvor-I Provor-I	Iridium SBD Up to 2000 CTD pts in a profile Ice detection function 
ARGO TS, 2000 m, Iridium	Arvor-I -RBR NEW	Iridium SBD Up to 2000 CTD pts in a profile Ice detection function 
ARGO TS, DO, 2000 m Argos & Iridium	Provor-DO Arvor-DO Provor-DO I Arvor-DO-I	CTD & DO, Argos2 CTD & DO, Iridium SBD, 2000 pts, Ice detection 
ARGO TS, DO 4000 m	Deep ARVOR	CTD & DO, Iridium SBD, 4000 pts, Ice detection 
BGC, TS, 2000 m	Provor CTS 4 Provor CTS5 NEW	BGC sensors : D O, Radiometer, fluorometers, ^{biogeochemical} transmissometer, nutrients , NOSS, pH Iridium rudics, 0.2 dBar resolution, Ice detection UVP6-LP on progress (CTS5 only) 
TS, DO, 400 m TS, Tu, Fl, DO, 400 m	Arvor C Arvor-Cm	Coastal applications (CTD & DO), Iridium SBD metric resolution



Nke BGC floats : PROVOR CTS4 and CTS5

PROVOR **CTS4** (« **PROVOR_III** » in Jcommops database) for BGC Core Argo mission

Mature float able to embed all 6 variables recommended by BGC-ARGO :

- ❏ CHL-A
- ❏ Backscatter (suspended particles)
- ❏ DO with in air measurement
- ❏ Nitrate
- ❏ pH
- ❏ PAR

5 floats with all these variables are now operating at sea (IMR, SIO)

6 more in recent future deployed by LOV, 5 for Univ. Of Tasmania,

1 for OGS, ...

More than 200 units deployed with various sensor equipments



Main features

- ❏ High sampling possibilities (5 independant zones per sensor in water column, high resolution (20 cm), specific treatment per zone and per sensor, with specific power mode
- ❏ Self ballasted float
- ❏ Ability to embed large battery pack for long life expectancy and contribution to core ARGO program in

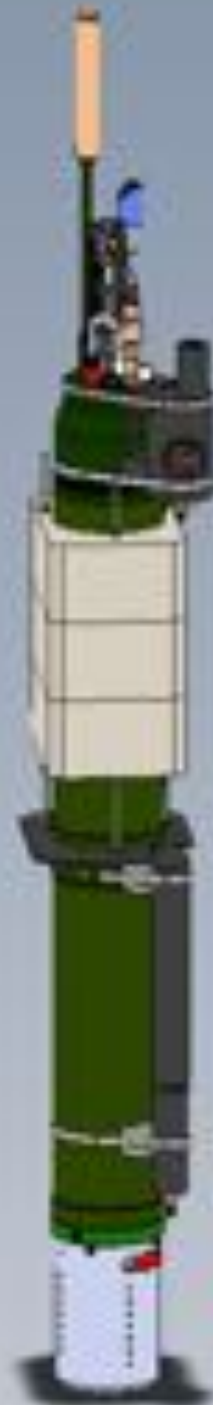

PROVOR CTS4 for BGC application

- Float dimensions
 - Overall length : 219 cm with antenna
 - Hull length 170 cm
 - Hull diameter 17,3 cm
 - Max diameter : 35 cm (damping collar)
 - Weight 40 to 55 kg depending on sensor equipment
- Environmental operating conditions
 - Max operating depth 2000 dBar
 - Operating temperature -2°C to 35°C
 - Operating life : up to 6 years at sea
 - Power supply Lithium cells
- Telemetry
 - Data transmission through iridium rudics
 - GPS positioning
 - Optimized duration at surface
- Buoyancy management
 - Principle oil ballast with high pressure pump
 - Large oil volume : 3 liter
 - Positioning accuracy +/- 30m

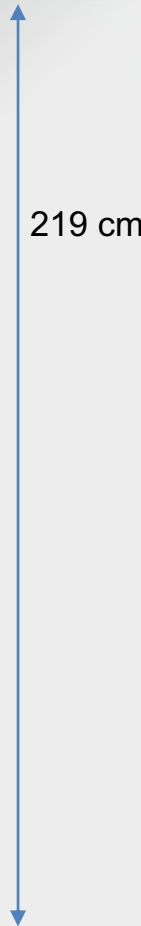
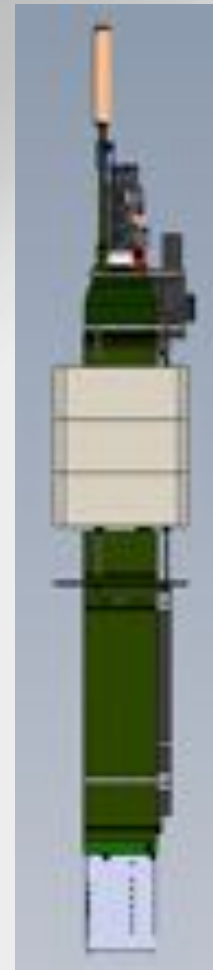

PROVOR CTS4 main features

- ❏ First float able to acquire at same time all 6 variables recommended by BGC ARGO (Chla, suspended particles, O₂, NO₃, pH, irradiance)
- ❏ Dimensions and payload capacity make this float a fully adequate platform for BGC application
 - ❏ large battery for both sensors & float to reach high number of profiles (up to 500 with specific parameter)
 - ❏ Two electronic boards architecture, increase sensor sampling & treatment possibilities, with at same time, high level of reliability for electronic board that deals with float control (cycle in water column & transmission)
- ❏ Robust hydraulic engine, offers to float to remain auto-ballasted whatever are density conditions of deployment's area
- ❏ High sampling resolution possible for all sensors (2 sec -> 20 cm as spatial resolution)
- ❏ Drift recording
- ❏ Ice detection function

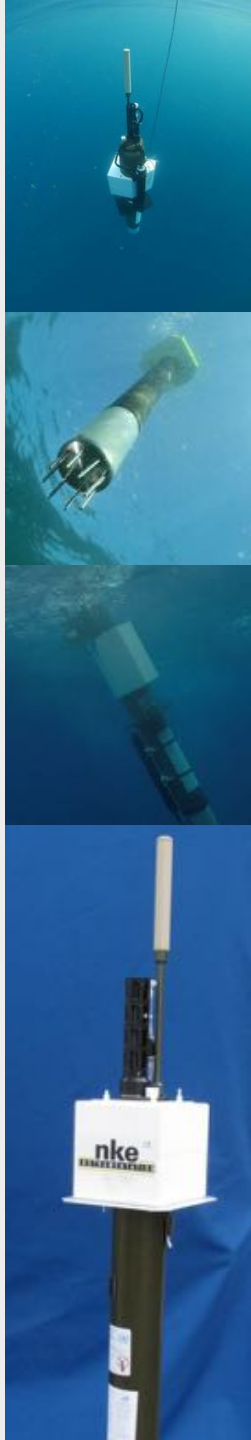

PROVOR CTS4 main features

- ▶ Deployed more than 200 floats (since 2012)
- ▶ More than 25 000 cumulated profiles
- ▶ Deployed in large density conditions and in ice-covered areas
- ▶ The standard float for “classical BGC need”

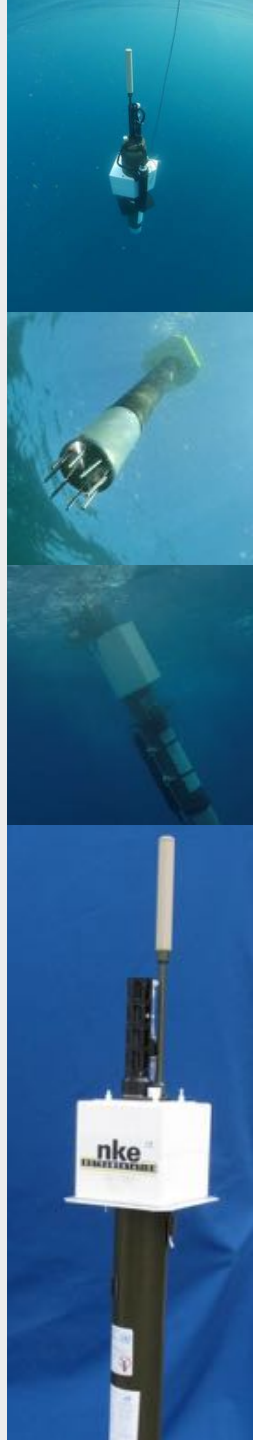

PROVOR CTS4 main features

Sensors embedded by float

Standard sensors

- ☑ CTD
- ☑ Dissolved oxygen
- ☑ Nutrients
- ☑ REM-A
- ☑ REM-B

☑ pH

Others sensors

- ☑ ECO-FLBBBCD-2k
- ☑ ECO-FLBB-2k
- ☑ Trilux
- ☑ Cyclops7
- ☑ Turbidimeter
- ☑ ...
- ☑ Your sensor ?

- Seabird SBE41CP
- Aanderaa Optode
- Seabird SUNA
- satlantic OCR504 +
- Wetlabs Eco-FLBBBCD-2K
- REM-A + Wetlabs
- Transmissometer
- CROVER7
- Seabird Seafet New

- Wetlabs
- Wetlabs
- Chelsea
- Turner Design
- Seapoint

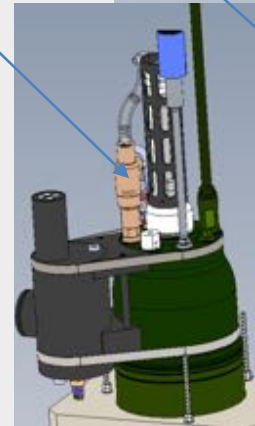
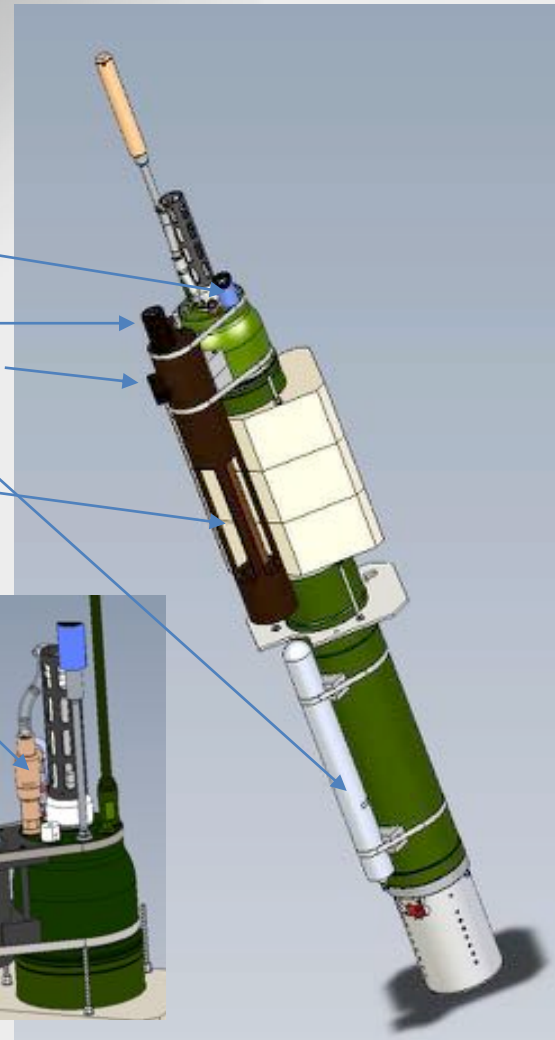

PROVOR CTS4 firmware & offered flexibility

Profiles setting

Up to 10 independent profiles per cycle

Each profile has specific :

- Drift & profile depth
- Day & hour at surface
- Transmission or not

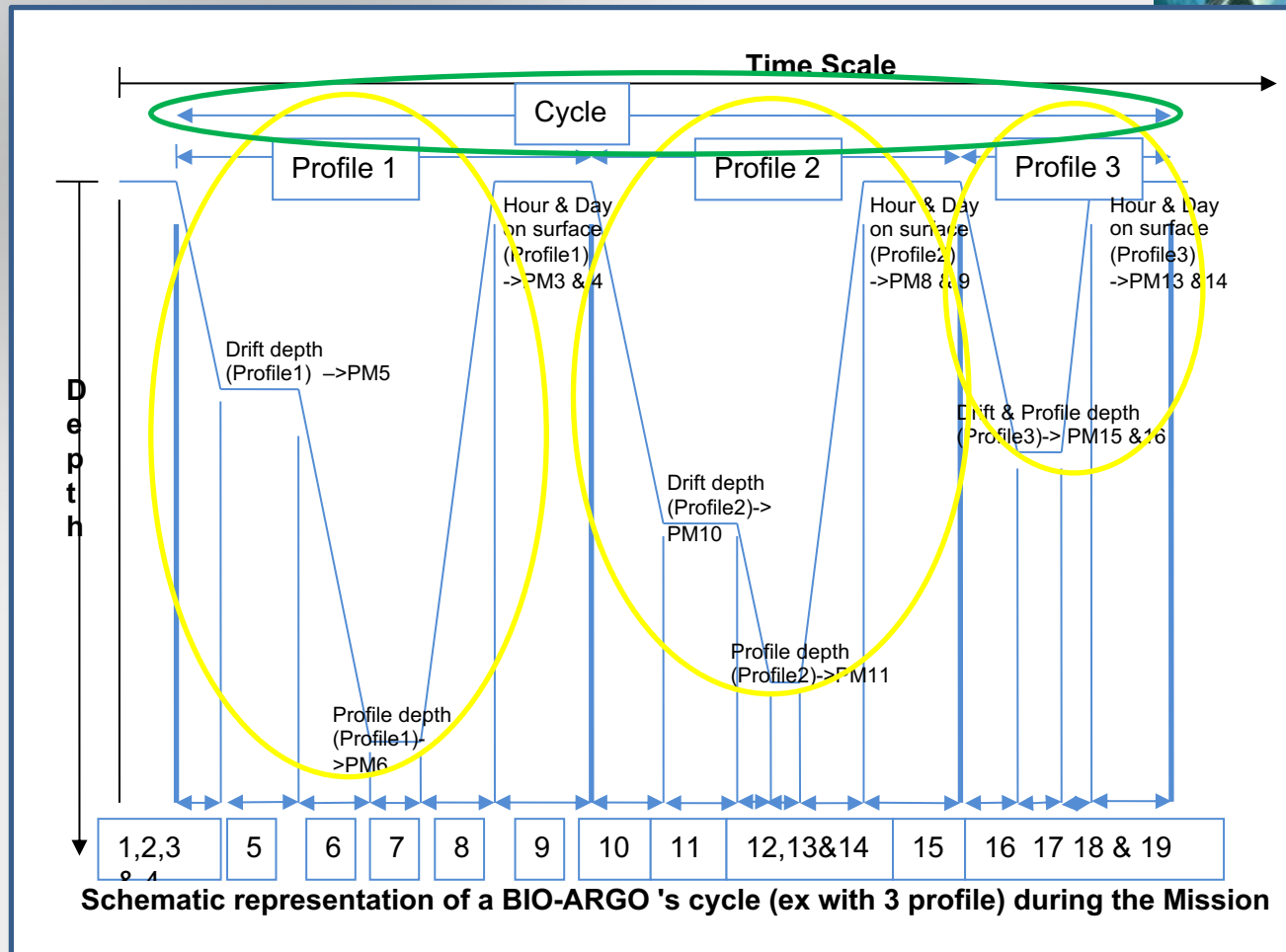

RELIABILITY

Longevity examples

- WMO 6901473 : **561 profiles** (4 profiles/cycle), from 2012 to 2016 – (CTD, DO, Chl-a, CDOM, backscatter, irradiance, transmissometer)
- WMO 6901439 : **455 profiles** (1 profile per cycle & per day), from 2012 to 2014 – (CTD, DO, Chl-a, CDOM, backscatter, irradiance)

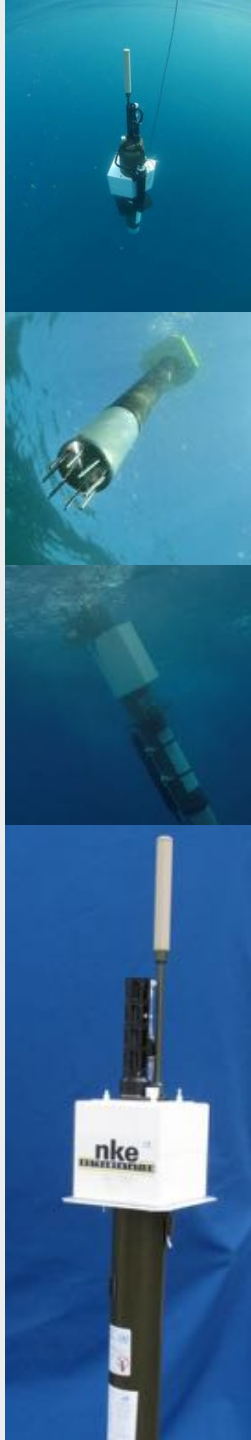

Example at sea : WMO 6901472

- ▣ Deployed on 23/10/2012 and still active
- ▣ 214 cycles @ 10 days (1 profile per cycle)
- ▣ Sensor equipment :
 - ▣ CTD (SBE41CP)
 - ▣ DO (4330)
 - ▣ Nutrient (SUNA)
 - ▣ REM-A (ECO-FLBBBCD & OCR504 for 3 irradiance and PAR)

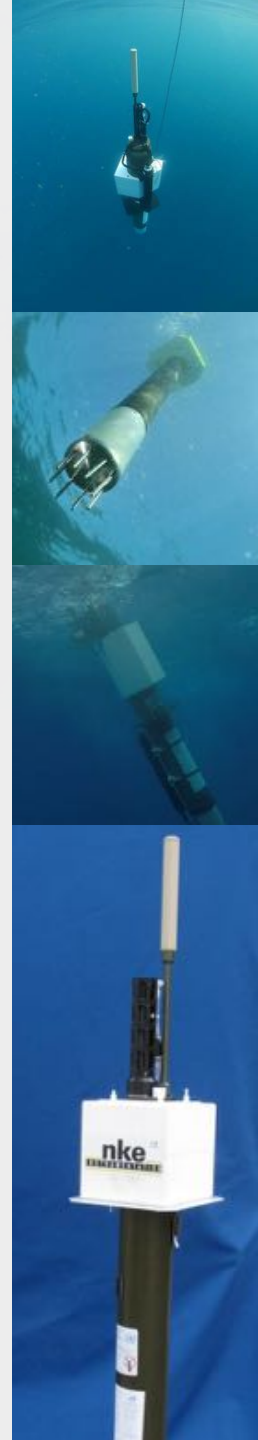





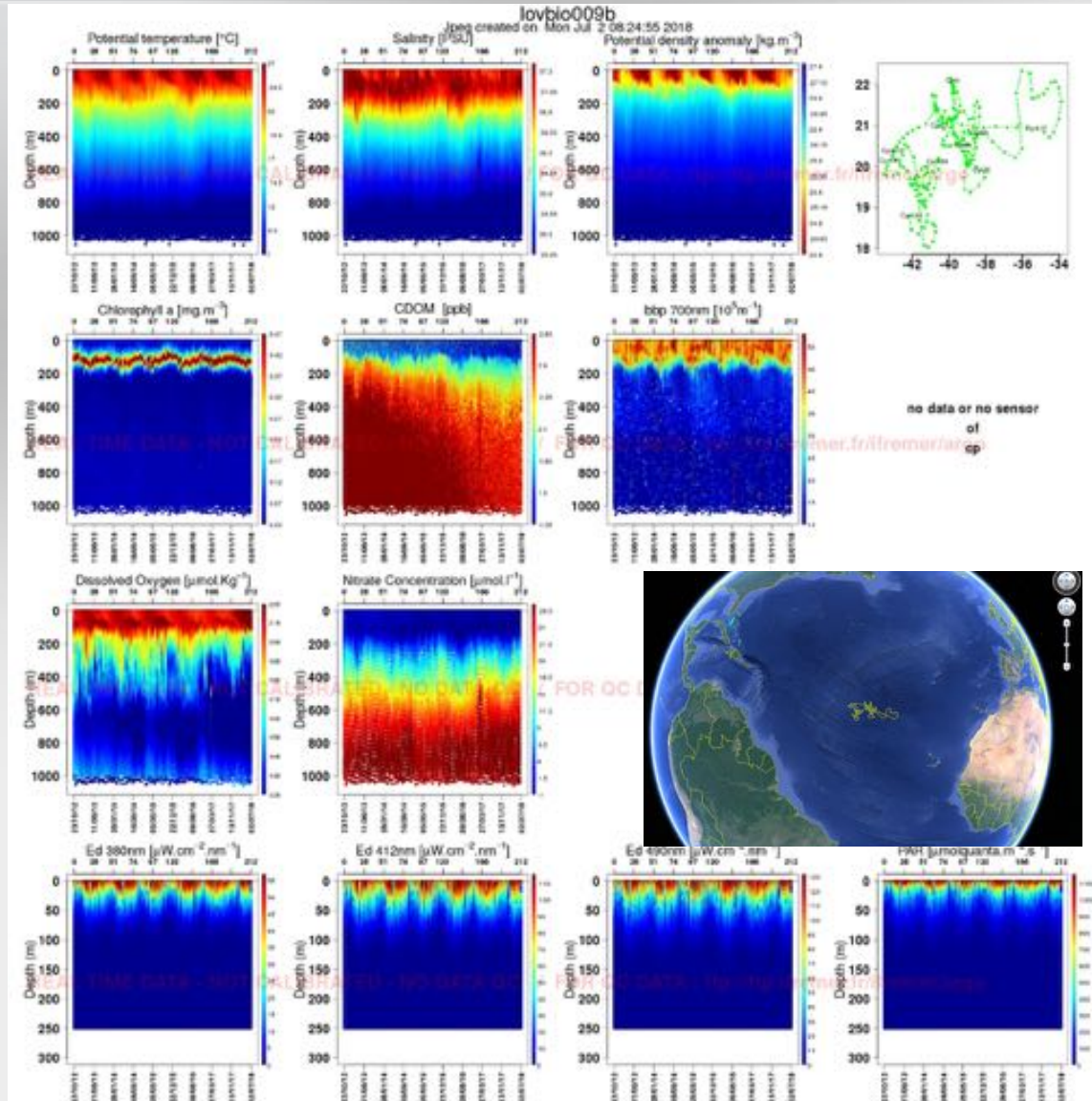

Example at sea : WMO 6901472

Deployed on
23/10/2012



Range of Floats

Type	Nke model	Comments
ARGO TS, 2000 m, Argos	Arvor-L, Arvor Provor CTS3	Argos 2 200 CTD points max per profile 
ARGO TS, 2000 m, Iridium	Arvor-I Provor-I	Iridium SBD Up to 2000 CTD pts in a profile Ice detection function 
ARGO TS, 2000 m, Iridium	Arvor-I -RBR NEW	Iridium SBD Up to 2000 CTD pts in a profile Ice detection function 
ARGO TS, DO, 2000 m Argos & Iridium	Provor-DO Arvor-DO Provor-DO I Arvor-DO-I	CTD & DO, Argos2 CTD & DO, Iridium SBD, 2000 pts, Ice detection 
ARGO TS, DO 4000 m	Deep ARVOR	CTD & DO, Iridium SBD, 4000 pts, Ice detection 
BGC, TS, 2000 m	Provor CTS 4 Provor CTS5 NEW	BGC sensors : D O, Radiometer, fluorometers, ^{biogeochemical} transmissometer, nutrients , NOSS, pH Iridium rudics, 0.2 dBar resolution, Ice detection UVP6-LP on progress (CTS5 only) 
TS, DO, 400 m TS, Tu, Fl, DO, 400 m	Arvor C Arvor-Cm	Coastal applications (CTD & DO), Iridium SBD metric resolution
Polar	PROVOR SPI	Polar application, TS, DO, NO ₃ , pH
Acoustic spectrum, 1000 m	Provor AC, AC2	Hydrophone, data processing, Iridium transmission

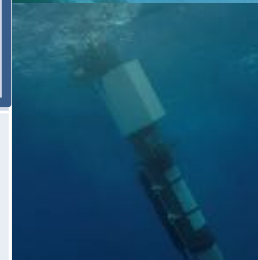
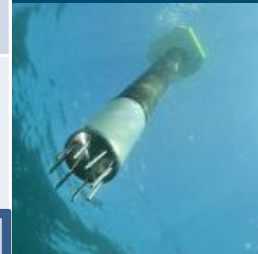
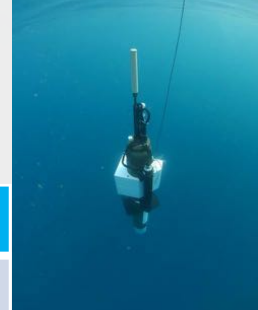

PROVOR CTS5 main features

- ◀ Dedicated to science application, with additional sensors or mission compared to standard BGC mission with 6 variables

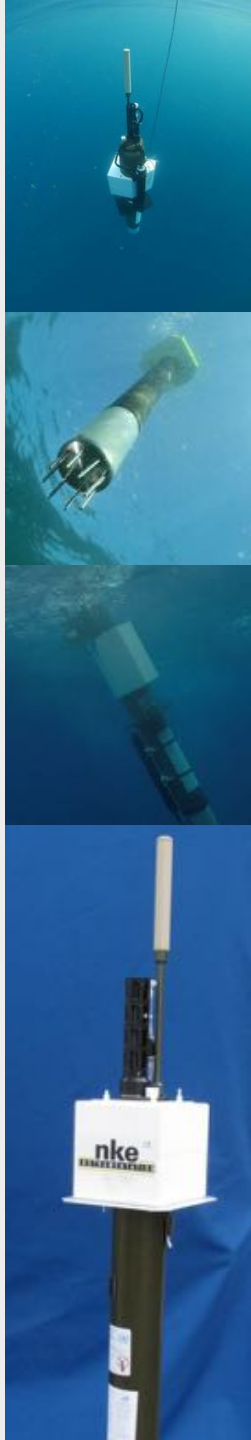

PROVOR CTS5 : Electronic architecture

2 Main boards (Float and sensors)

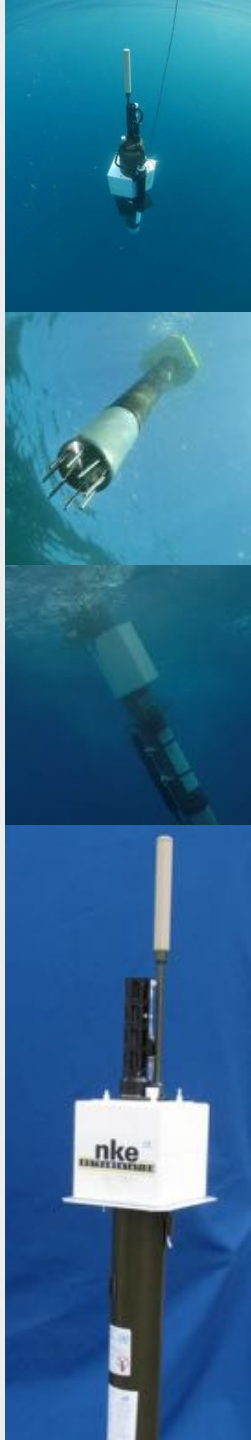
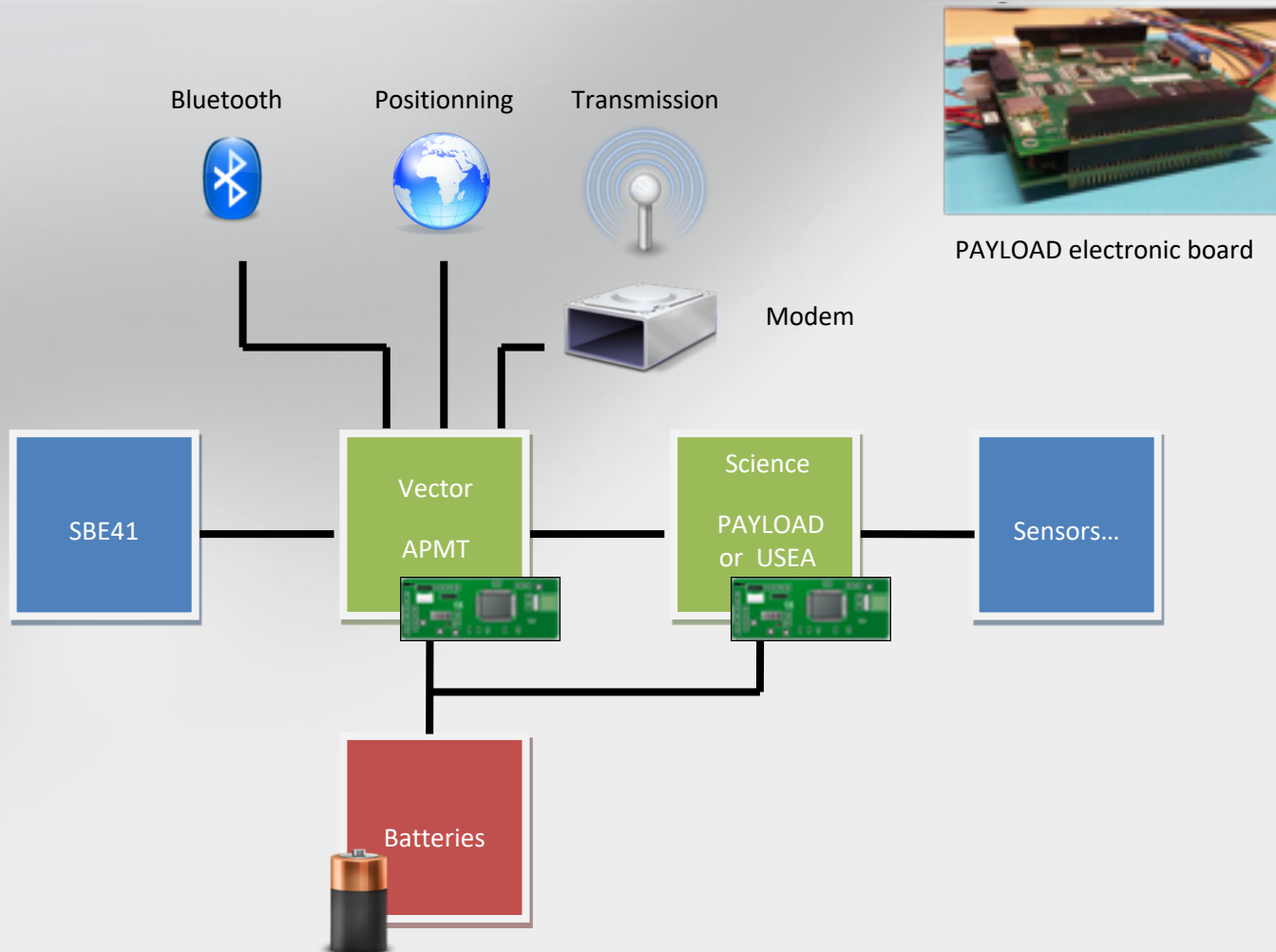

PROVOR CTS5 for R&D and demanding application

2012 -> 2019 : PROVOR CTS5 (« PROVOR_IV » in Jcommops Database)

Based on a couple of board : APMT designed by nke for float (displacement, Transmission, CTD, ...) and 2nd board « PAYLOAD » developed on LOV request for scientific application, with driver coded by LOV Team. Developed during Naos project with LOV and Takuvik teams

Initial main goals were :

- Flexibility and ability to quickly test prototype equipped with new sensors or new mission scheme, without need to request development to nke
- Offers also possibility to get influence of measurement on float's mission Scheme

Several application at sea since 2014 : PRO-ICE, PROVAL (Validation of Ocean Colour Sattelite)



PROVAL, a new float for radiometric measurements

Slide with LOV credits (E. Leymarie)

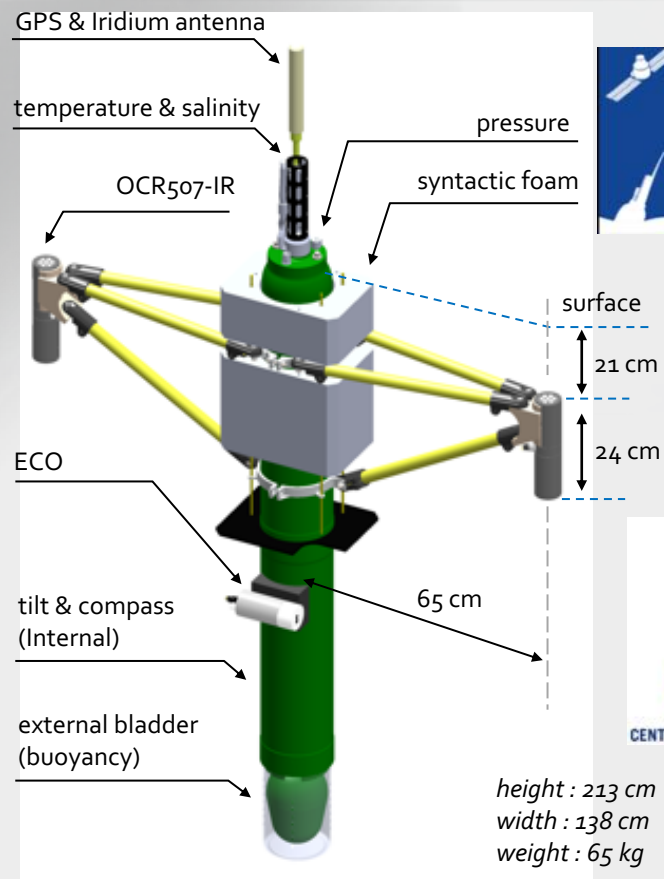
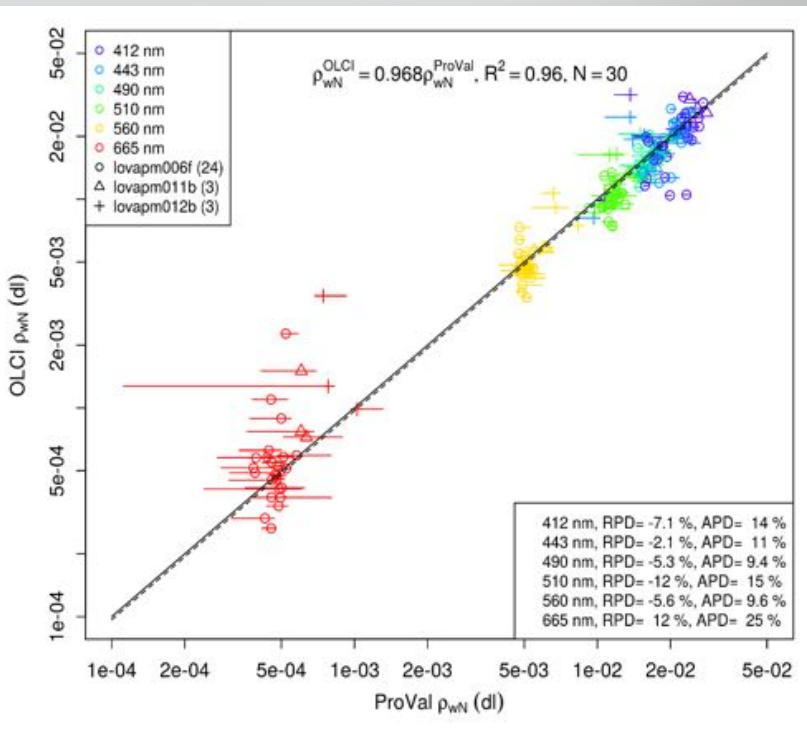

Already 3 floats and more than 600 profiles. *Frontiers in mar. Sc.* LOV credits
<https://www.frontiersin.org/articles/10.3389/fmars.2018.00437/full>



PRO-ICE : a BGC float for arctic condition

Joint work from LOV and C. Marec, J. Lagunas, E. Rehm and M. Babin from Takuvik

- ✓ Ice avoidance : ISA adapted to Baffin Bay, Altimeter and date criteria programmed on the LOV acquisition board
- ✓ Change of configuration under-ice

TAKUVIK



Crédit P. Bourguain

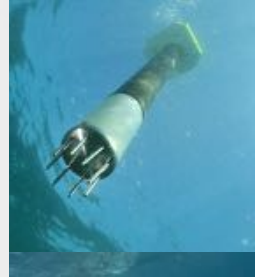
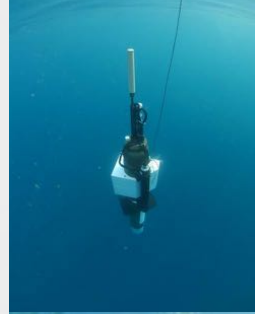
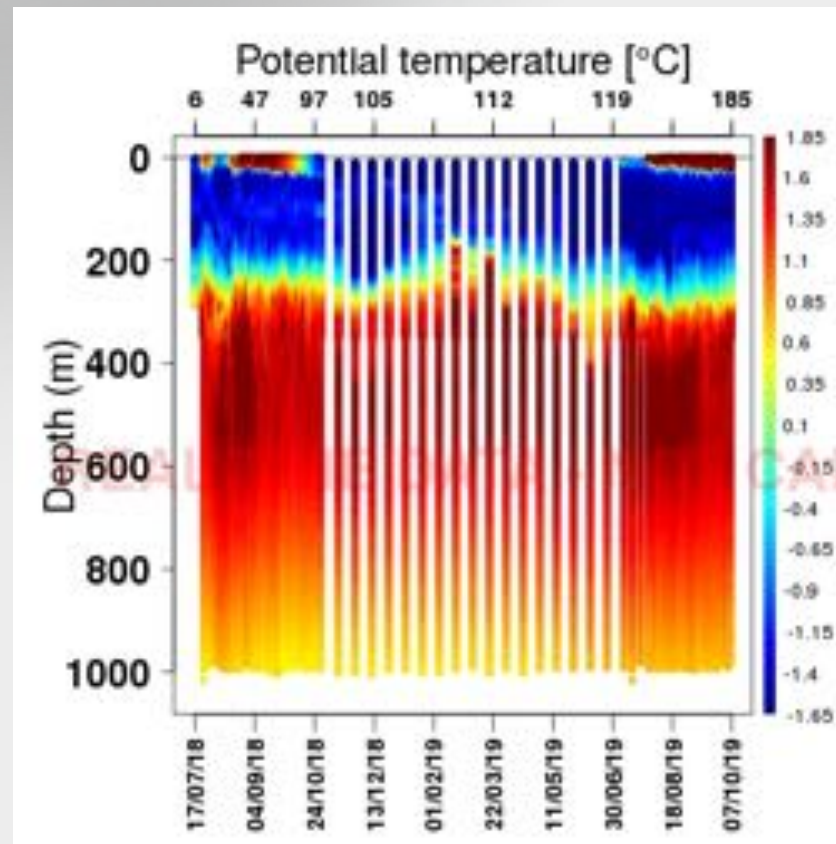

PROVOR CTS5 design up to 2019

2012 -> 2019 : PROVOR CTS₅ (« PROVOR_IV »)

- This float has shown promising possibilities, but by design, is more difficult to offer to a larger scientific community.
- Reason is that nke do not have hand on Firmware for sensors acquisition. In a context of high reliability requirements for ARGO and BGC-ARGO application, this float's type is difficult to propose as answer in user's tender

Going from this situation, main question was

« how could nke combine both possibilities

- New performance with flexibility and ability for user to developed its own driver for sensor evaluation
- and at same time offer a float that gives new performance (mission scheme, file system, improved rudics transmission rate, ...) and all improvment introduced ? »

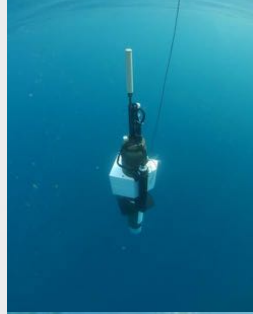

PROVOR CTS5 since 2020

2020 -> New PROVOR **CTS₅** (with USEA acquisition board) becomes « **PROVOR_V** » in Jcommops Database



USEA internal architecture

Initial Choice : 2 cores in acquisition board !

- μ C Core includes all standard BGC sensor drivers coded by nke for reliability requirements (coming from historical result on CTS₄) and also UVP6-LP driver (on progress)
- Linux Core will enable to any user to code its own driver for evaluation and test application of new sensor or new mission scheme

Float can becoming now a standard offer float with 6 variables recommended by BGC-ARGO (+UVP6-LP)

And

Also with additional possibilities (any oceanographic sensor, ...)

Both goals are now possible



USEA new electronic our answer to both wishes



Initial Choice

- Limit to 6 Sensors + SBE
- Extension Board possible for more sensors

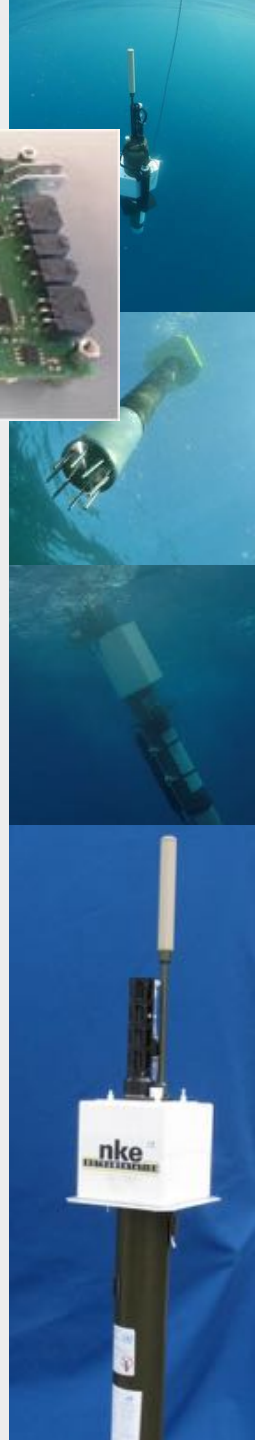
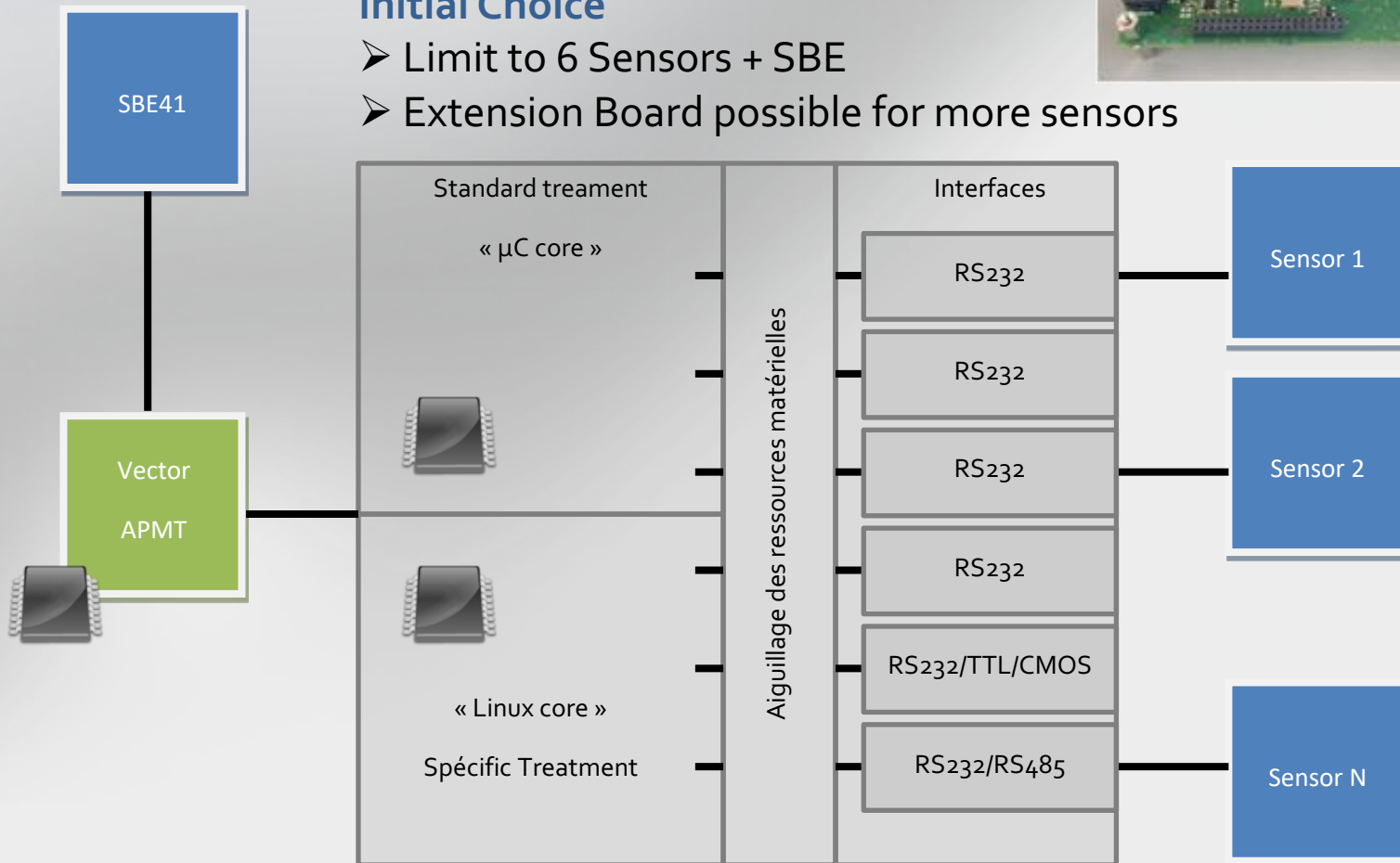

PROVOR CTS5 new features

Flexibility for mission scheme

- Mission described by an « Equation »
- Iridium Telecommand modification
- Modification pre-programmed by script

Transmission and storage

- Additional External Memory (micro-SD)
- Improved RUDICS Rate (typ. > 14 KB/min)

Large Sensor power supply possibilities

- Ex : DO Power supply with +5V to enable Continuous power (no self-heating phenomenon at this voltage)

File System instead of line command

- Configuration file
- Treated Data File
- Technical Data File
- Metadata File
- Traces File

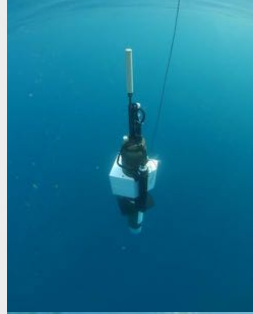

PROVOR CTS5 new features

User interface

- TCP/IP link by Bluetooth (FTP, TELNET)
- Graphical User Interface for configuration
- Decoding Library (*.dll et Linux)

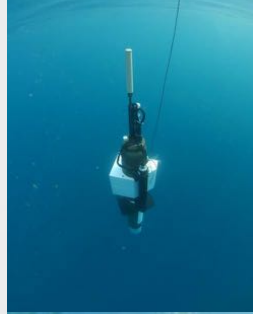
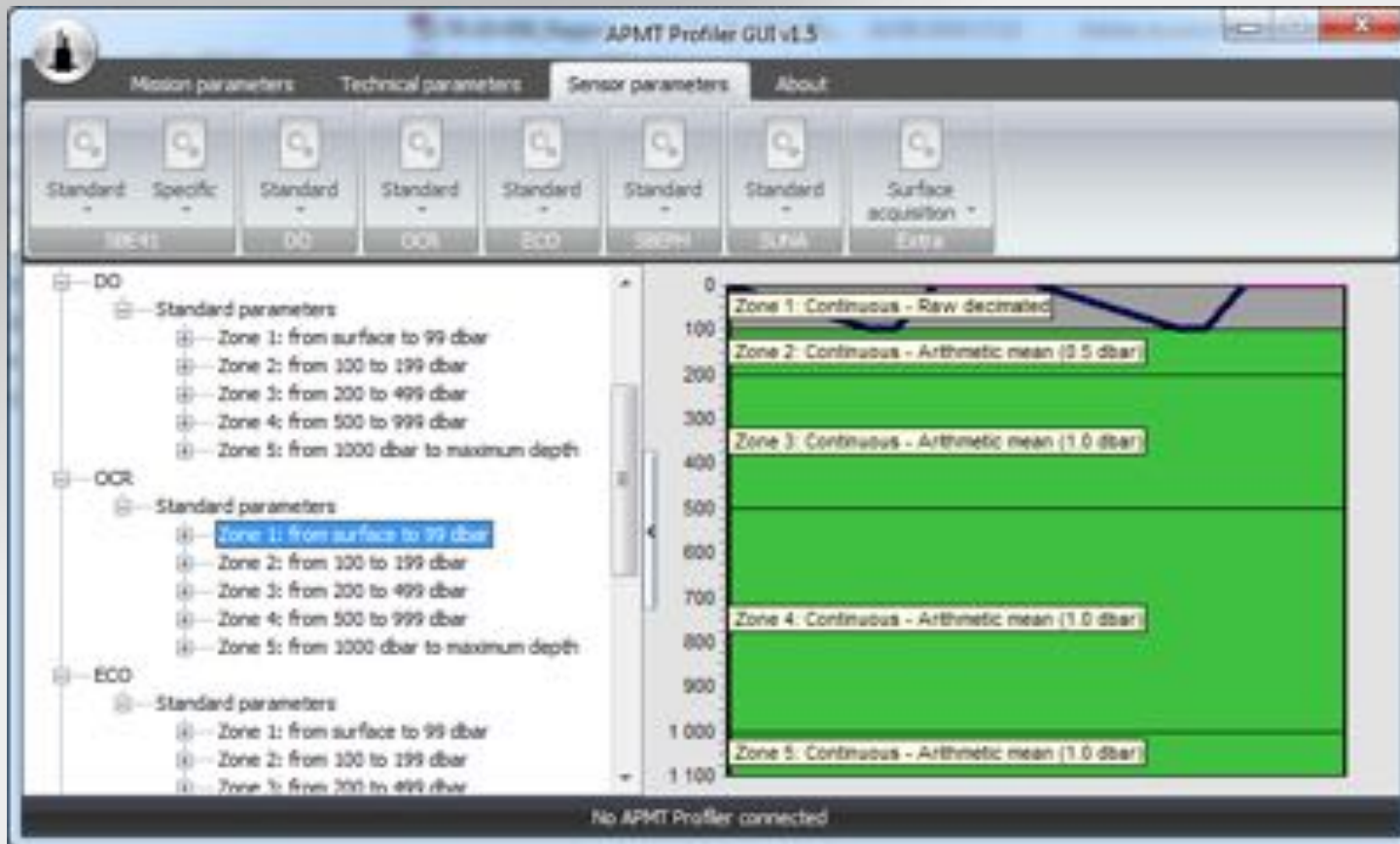

PROVOR CTS5 new features

Navigation

- « Near surface » and « In Air » Phases and specific transmitted packet to comply with Dissolved oxygen measurement recommendation

CTD Data acquisition

- 1 Hz for SBE41 (instead of 0,5 Hz), better spatial resolution : 10 cm

Data Treatment

- Average with 0,5 dBar Slice thickness
- Raw Data with decimation at 0,1/0,2/0,5 and 1,0 dBar
- Timestamp for all Data transmitted



PROVOR CTS5 new features

Example of Metadata file

```
C:\Users\jsagot\MICREL\Desktop\3e82_017_00_metadata.xml - Notepad++
Fichier Édition Recherche Affichage Encodage Langage Paramétrage Macro Exécution Compléments Documents ?
3e82_017_00_metadata.xml
1 <FLOAT>
2 <PROFILER SN="AABBCC-DDEEFF" Model="PROVOR-V"/>
3 <TELECOM Type="IRIDIUM" CID="8988169234000799353"/>
4 <HARDWARE>
5 <CONTROL_BOARD Model="APMT" Firmware="1.07.019"/>
6 <MEASURE_BOARD Model="USEA" Firmware="1.00.019"/>
7 </HARDWARE>
8 <SENSORS>
9 <SENSOR_DO>
10 <SENSOR SN="03014" Model="DO4330"/>
11 <PHASE_COEFF c0="9.500000e-02"/>
12 <SVU_FOIL_COEFF c0="2.749372e-03" c1="1.217100e-04" c2="2.062590e-06" c3="1.655341e+02" c4="-1.938229e-01" c5="-3.551454e+01" c6="3.269046e+00"/>
13 </SENSOR_DO>
14 <SENSOR_OCR>
15 <SENSOR SN="00199" Model="OCR504"/>
16 <CHANNEL_01 a0="2.14749953810e+09" a1="1.62809288939e-07" im="1.161e+00"/>
17 <CHANNEL_02 a0="2.14759027190e+09" a1="2.01687699668e-07" im="1.368e+00"/>
18 <CHANNEL_03 a0="2.14744101360e+09" a1="1.99112996634e-07" im="1.365e+00"/>
19 <CHANNEL_04 a0="2.14694048490e+09" a1="3.27335128658e-06" im="1.359e+00"/>
20 </SENSOR_OCR>
21 <SENSOR_ECO>
22 <SENSOR SN="02311" Model="ECO3"/>
23 <CHANNEL_01 sf="7.500e-03" dc="46"/>
24 <CHANNEL_02 sf="1.754e-06" dc="47"/>
25 <CHANNEL_03 sf="8.760e-02" dc="44"/>
26 </SENSOR_ECO>
27 <SENSOR_SUNA>
28 <SENSOR SN="00327" Spectrum="Output pixels 34-75"/>
29 <SUNA_BOARD Firmware="2.2.13"/>
30 <SPECTROMETER spintper="550"/>
31 </SENSOR_SUNA>
32 <SENSOR_SBE41>
33 <SENSOR SN="08959" Model="SBE41-CP"/>
34 <SENSOR_PRESSURE SN="004978241"/>
35 </SENSOR_SBE41>
36 </SENSORS>
37 </FLOAT>
length: 2048 lines: 38 Ln: 4 Col: 15 Sel: 0 | 0 Dos\Windows UTF-8 INS
```

PROVOR CTS5 sensor driver implemented

Integrated on « μ C Core»

- Detection and Automatic Sensor identification
- Standard Sensor Drivers
 - DO-4330 et DO-3835
 - OCR-504 et OCR-507 (7/14 channels)
 - ECO (1/2/3 channels)
 - c-ROVER
 - SUNA (spectrum 45/90)
 - SBE-pH
 - UVP6-LP
 - ...
 - ECO-V2 Soon

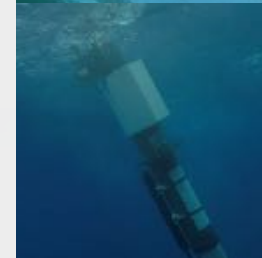
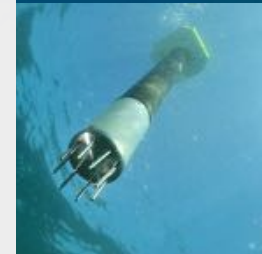
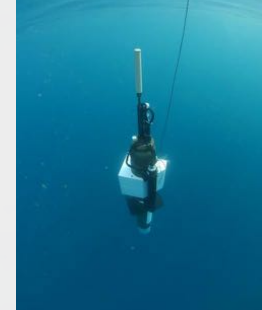

UVP6-LP on PROVOR CTS5

Underwater vision Profiler (UVP6-LP) (CNRS Patent) developed by LOV and manufactured by Hydroptic
UVP6-LP is designed to study large (>100 µm) particles and zooplankton simultaneously and to quantify them in a known volume of water. The UVP system makes use of computerised optical technology with custom lighting to acquire digital images of zooplankton IN SITU down to depths of 6000m.

UVP6-LP specific features:
miniaturized and low price version of the UVP5
designed for low speed, limited space and low power vectors like profiling floats, gliders, floats, moorings, AUVs...
3,2 Kg in air / 1,5 kg in water
6000 m rated

Compatible with ECOTAXA <http://ecotaxa.obs-vlfr.fr/part/>

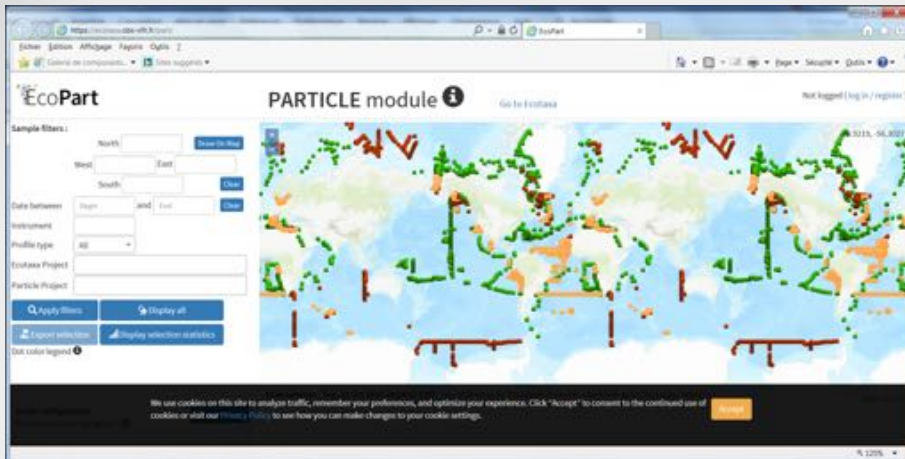
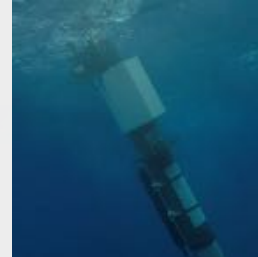
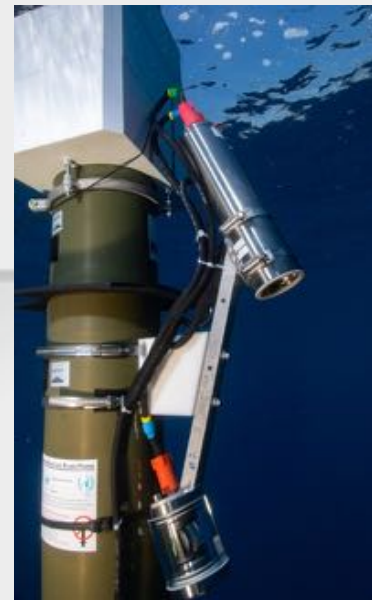

UVP6-LP on PROVOR CTS5

Low power, image based, particle size counter (18 size class, 64 to 4100 μm)

Octopus NPart_Class1-6

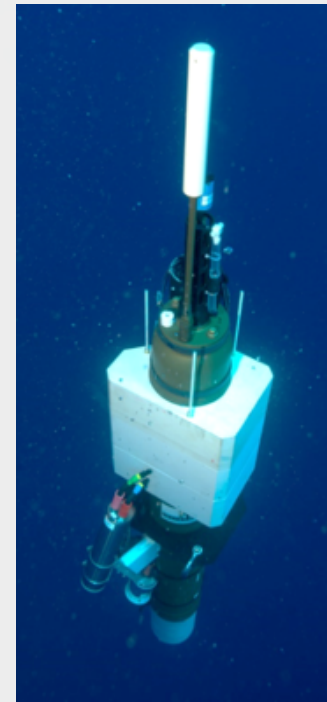
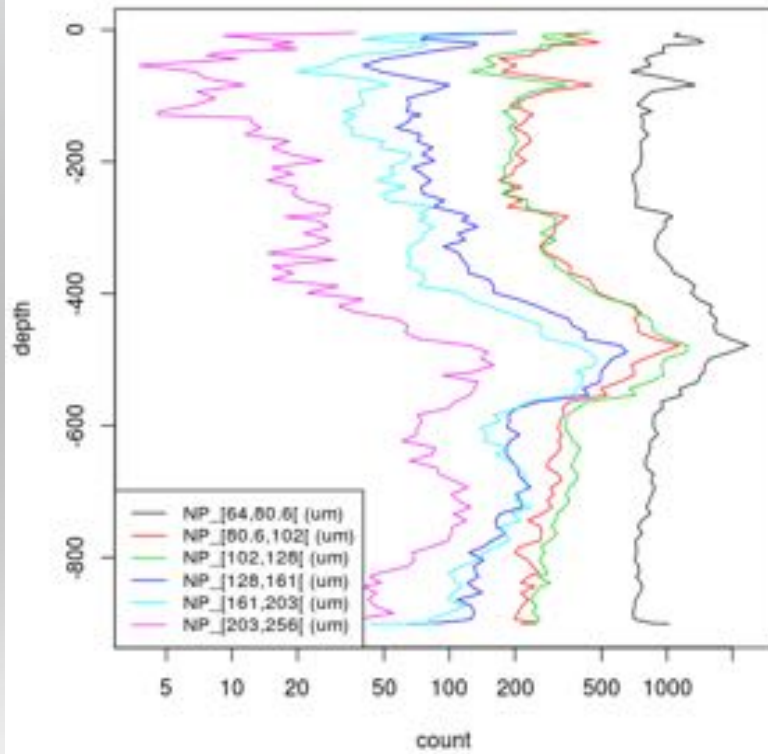

Project
GOPPI

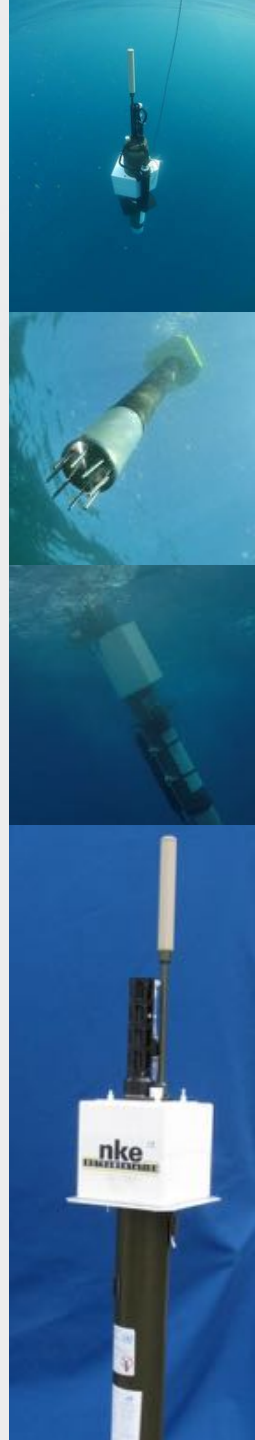

Thank you for your attention!

Jérôme Sagot
Head of Profiling Float Activity
jsagot@nke.fr

nke INSTRUMENTATION

Rue Gutenberg
ZI de Kérandré
56700 Hennebont

+33 (0)2 97 36 41 31
www.nke-instrumentation.com

