



Provor BGC floats and sensors

Hervé Claustre & LOV TEAM & NKE
Laboratoire d'océanographie de Villefranche
Villefranche-sur-mer France

Biogeochemical-Argo topics

Research topics

- Carbon uptake
- OMZs and nitrate cycling
- Acidification
- Biological carbon pump
- Phytoplankton communities

Management topics

- Living marine resources
- Carbon budget verification

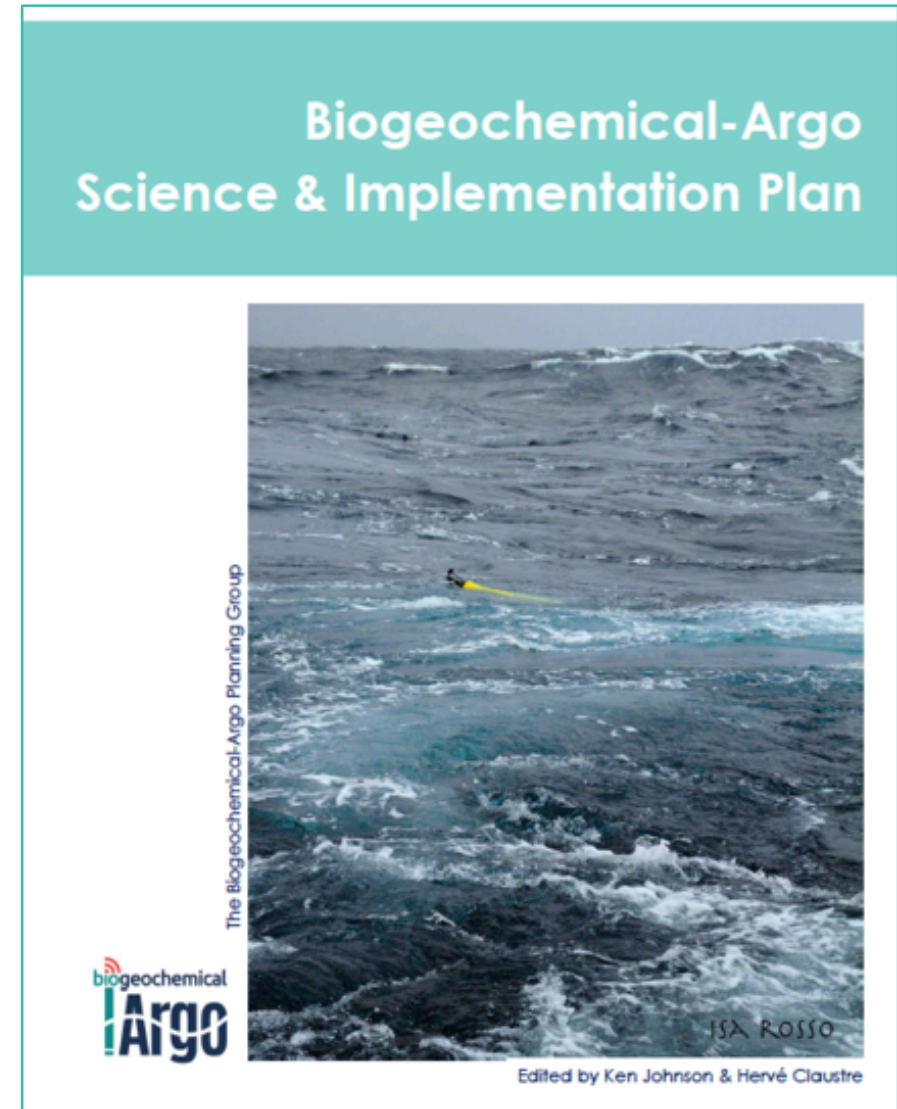

Biogeochemical-Argo core variables

- O_2
- NO_3
- pH
- Chl a
- Suspended particles
- Downwelling irradiance

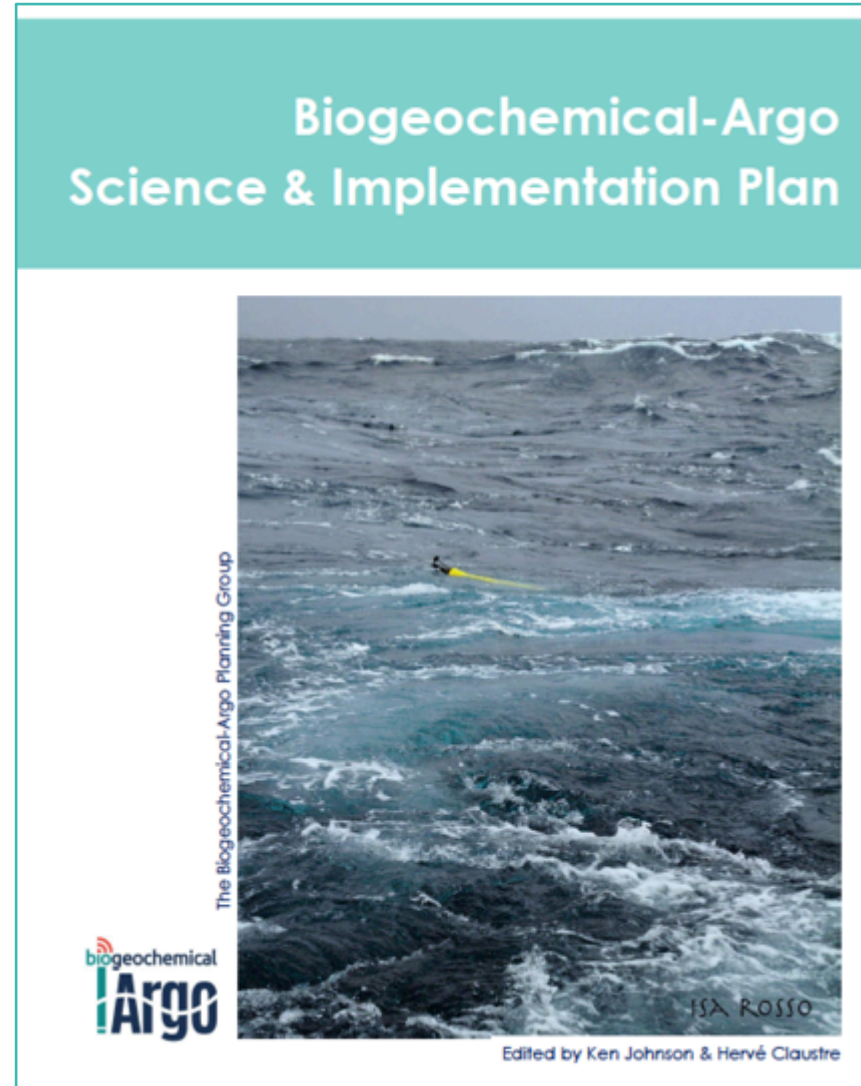

<http://biogeochemical-argo.org>

Three main BGC-Argo platforms

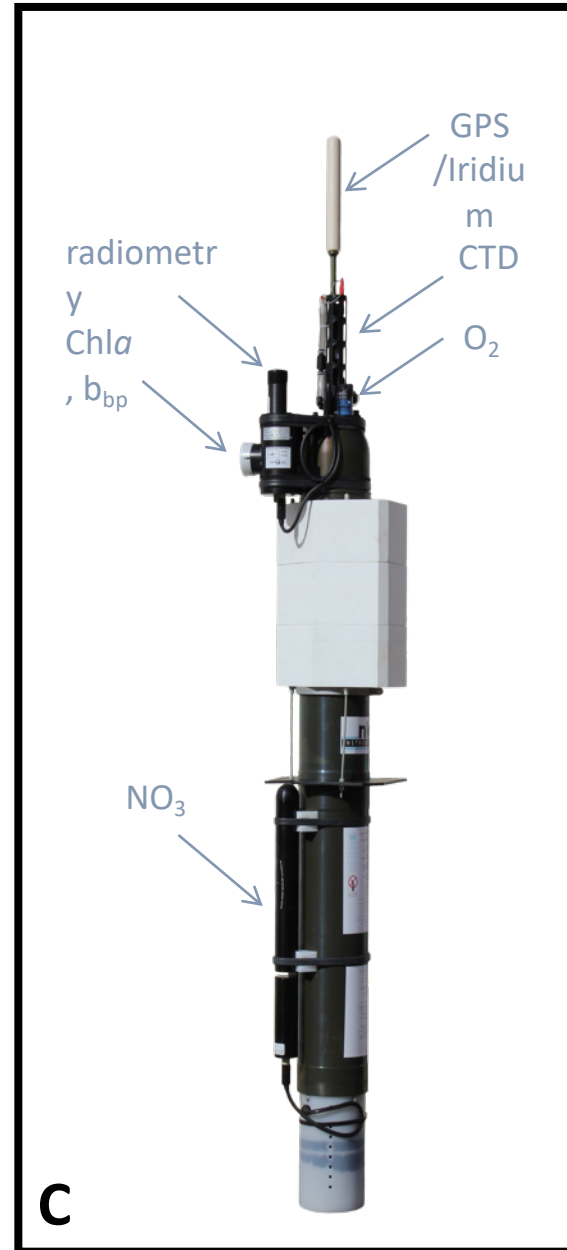
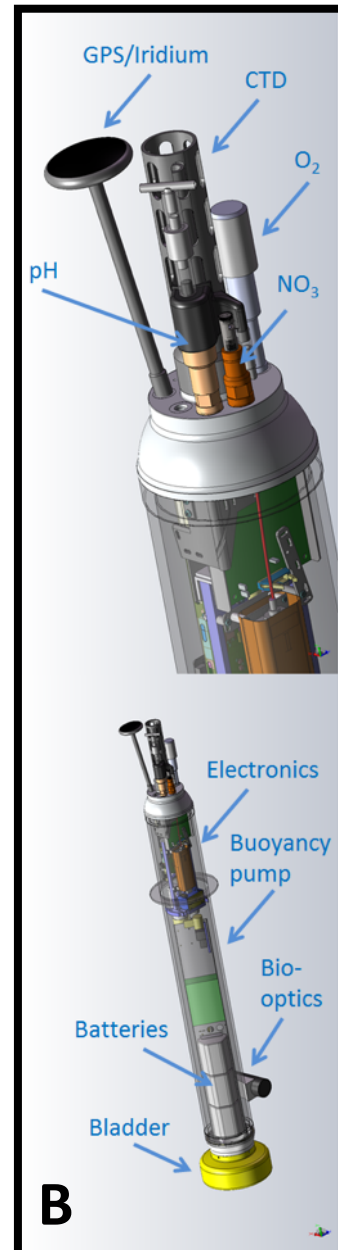

Roemmich et al., 2019

The BGC-Argo float we « upgraded » with NKE



■ Measurements

- PAR, Ed(380), Ed(412), Ed(490)
- $b_{bp}(700)$
- Chla fluorescence
- O₂
- NO₃
- pH
- $c_p(660)$
- CDOM fluorescence

■ Missions

- Temporal resolution configurable: from **diel cycle** to Argo 10 day cycling mode: adaptative sampling strategy
- Vertical configuration configurable: **up to 0.1m** resolution



~six-year time-serie

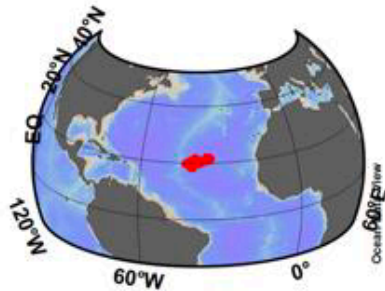
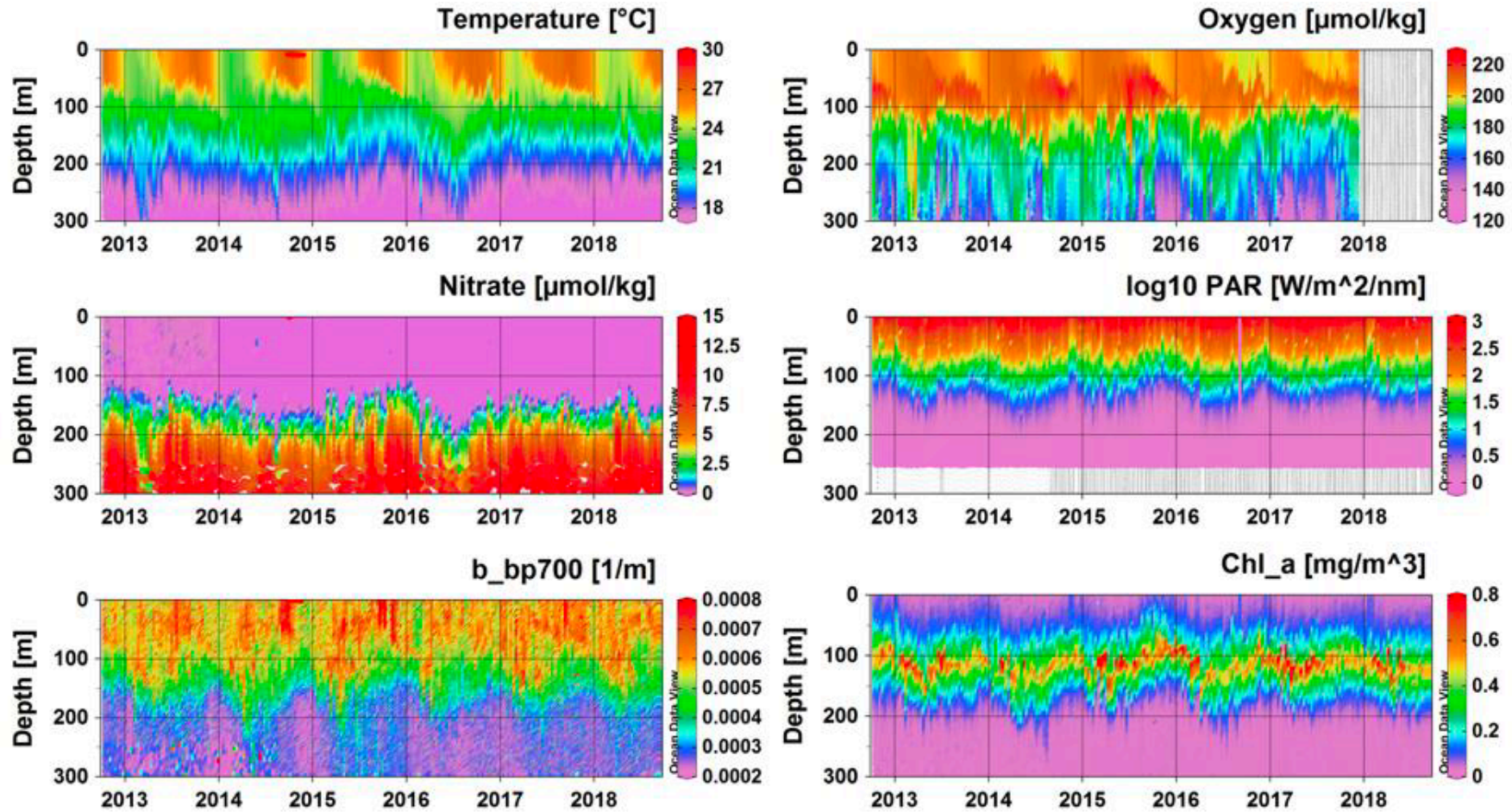

OUTLINE

- **Past** : some results with respect to the “specificities” of PROVOR ...
...and the way of using it (Biological Carbon Pump and Phytoplankton communities)
 - Transmissiometry
 - Measurements during drift
 - Radiometry
 - High vertical resolution
 - High temporal resolution
- **Future** : balancing Argo monitoring rules with the need for developing BGC-Argo process studies at specific scales and implement new sensors (Living marine resources)

Tranmissiometry: why c_p measurements are interesting ?

- Tranmissiometry allows to measure c_p , the particle attenuation coefficient.
- As first order (and as for b_{bp}), c_p is a proxy for suspended particles and POC (extensive literature)
- But c_p , when combined to b_{bp} , can allow deriving the so-called backscattering ratio which gives access to the nature of particles (refractive index, e.g. high for calcite)
- Specific applications on float includes:
 - Proxy for carbon flux
 - Combined with other measurements: retrieval of phytoplankton communities

RESEARCH ARTICLE

10.1002/2017JC013067

Key Points:

- Calibration of physical and optical data from the SOCLIM cruise in terms of plankton assemblage in the Southern Ocean (SO)

Plankton Assemblage Estimated with BGC-Argo Floats in the Southern Ocean: Implications for Seasonal Successions and Particle Export

Mathieu Rembauville¹ , Nathan Briggs¹, Mathieu Ardyna¹ , Julia Uitz¹, Philippe Catala², Cristophe Penkerc'h¹, Antoine Poteau¹ , Hervé Claustre¹ , and Stéphane Blain²

- Same optical sensors on float and on CTD rosette
 - Discrete water sample for cytometry, microscopy (+ sizing), POC
- => Data base of optical proxies and plankton fraction contribution to POC

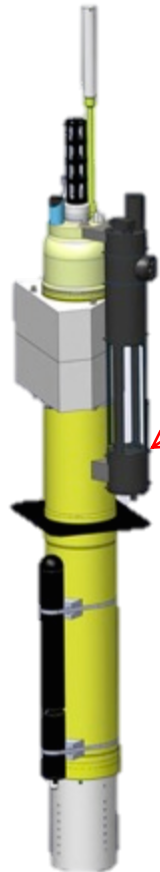

Chl
 b_{bp}
 c_p

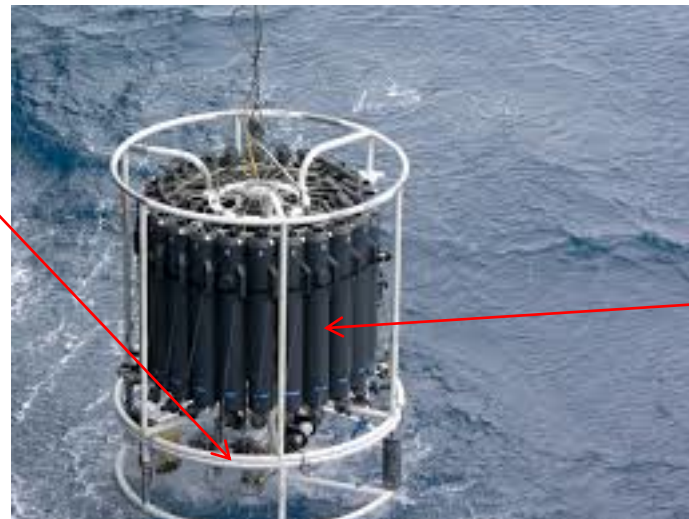

- POC
- Plankton counting, identification and sizing (microscopy and flow cytometry)

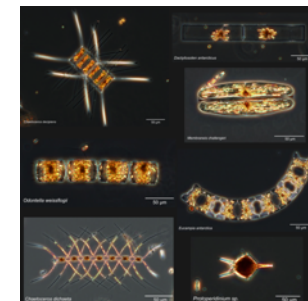

NIPALS (nonlinear iterative partial leastsquares)

Tranmissiometry: Phytoplankton community composition

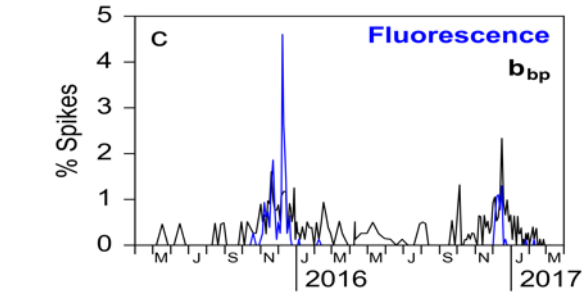
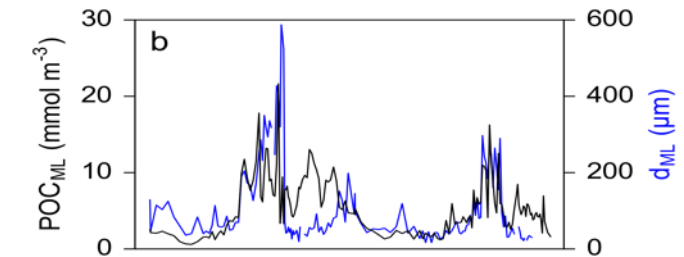
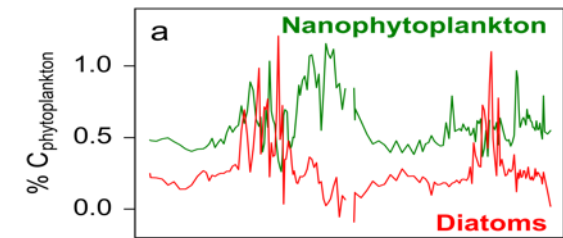
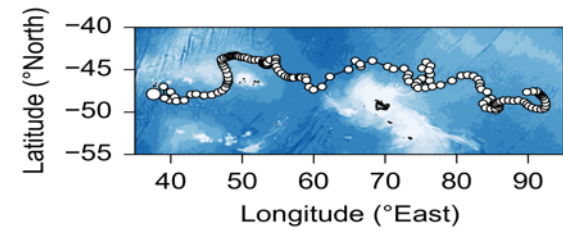
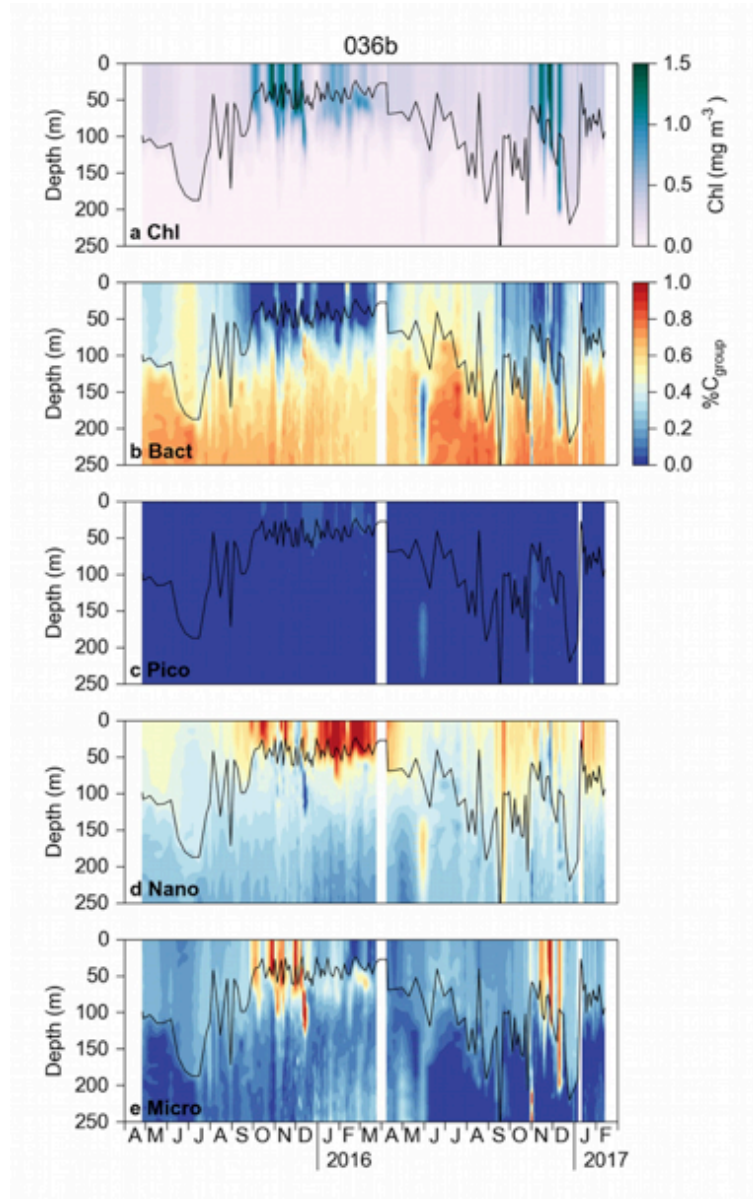

Transmissiometry and sinking particles (gravitational pump): The optical sediment trap techniques

Carbon flux from bio-optical profiling floats: Calibrating transmissometers for use as optical sediment traps

Meg Estapa^{a,*}, Colleen Durkin^{b,1}, Ken Buesseler^b, Rod Johnson^c, Melanie Feen^a

Deep-Sea Research Part I 120 (2017) 100–111

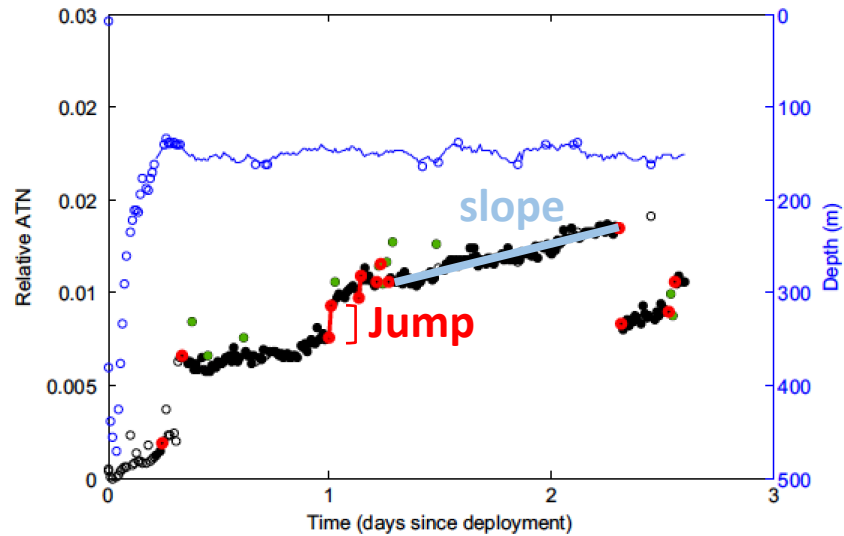

Slope (steady flux) and cumulative jumps (episodic flux) over a given period have units of $\text{m}^{-1} \text{d}^{-1}$ which can be converted into carbon fluxes

Global Biogeochemical Cycles

RESEARCH ARTICLE
10.1029/2018GB006098

Direct Observations of Biological Carbon Export From Profiling Floats in the Subtropical North Atlantic

Key Points:
• Profiling floats captured strong

M. L. Estapa¹, M. L. Feen^{1,2}, and E. Breves¹

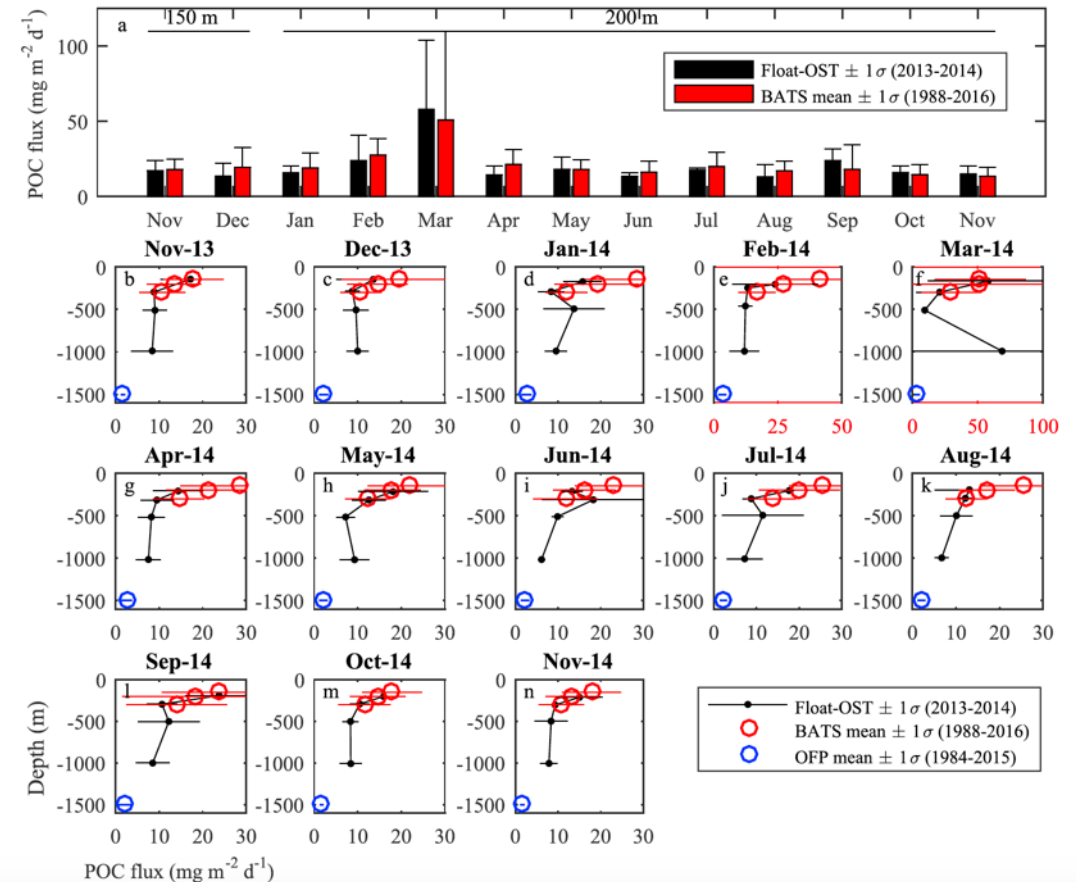

Transmissiometry : Optical Sediment Traps time-serie in the Southern Ocean

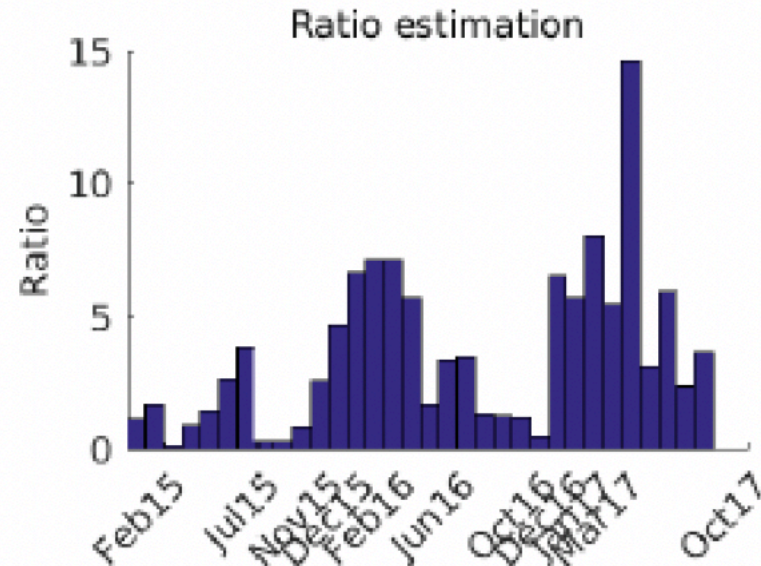
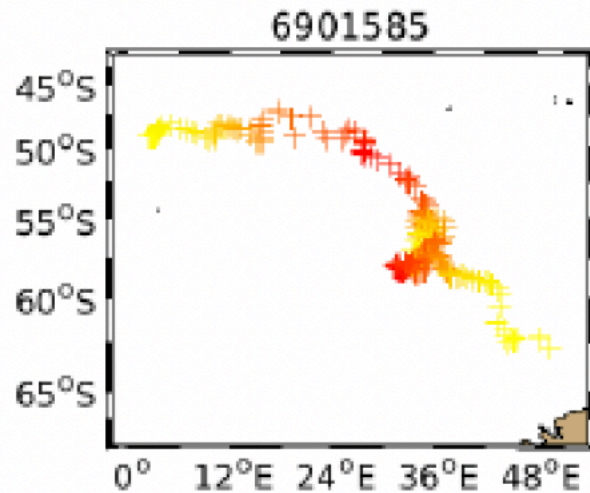
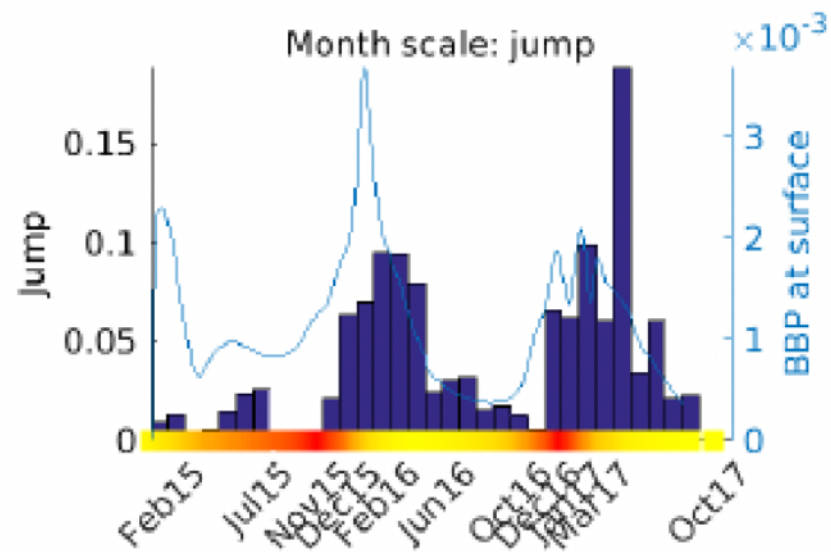
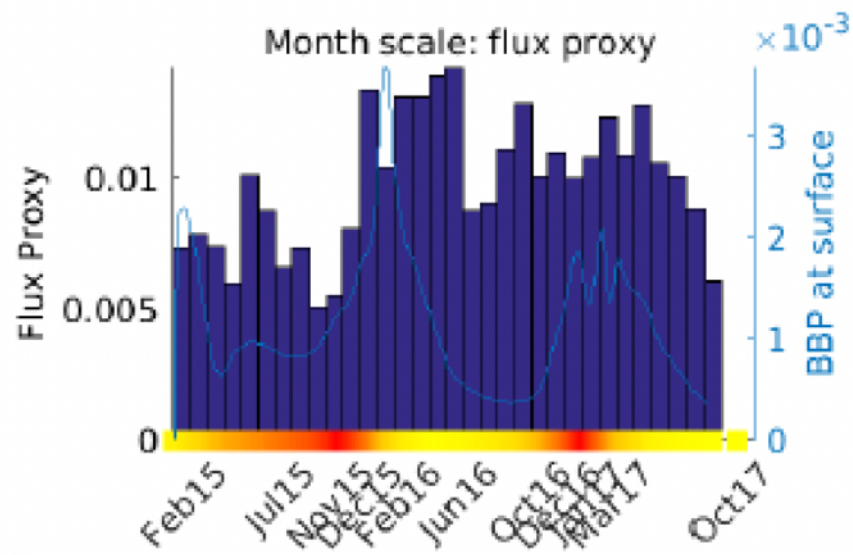

Monitoring during the drift: propagating satellite information to export at 1000m

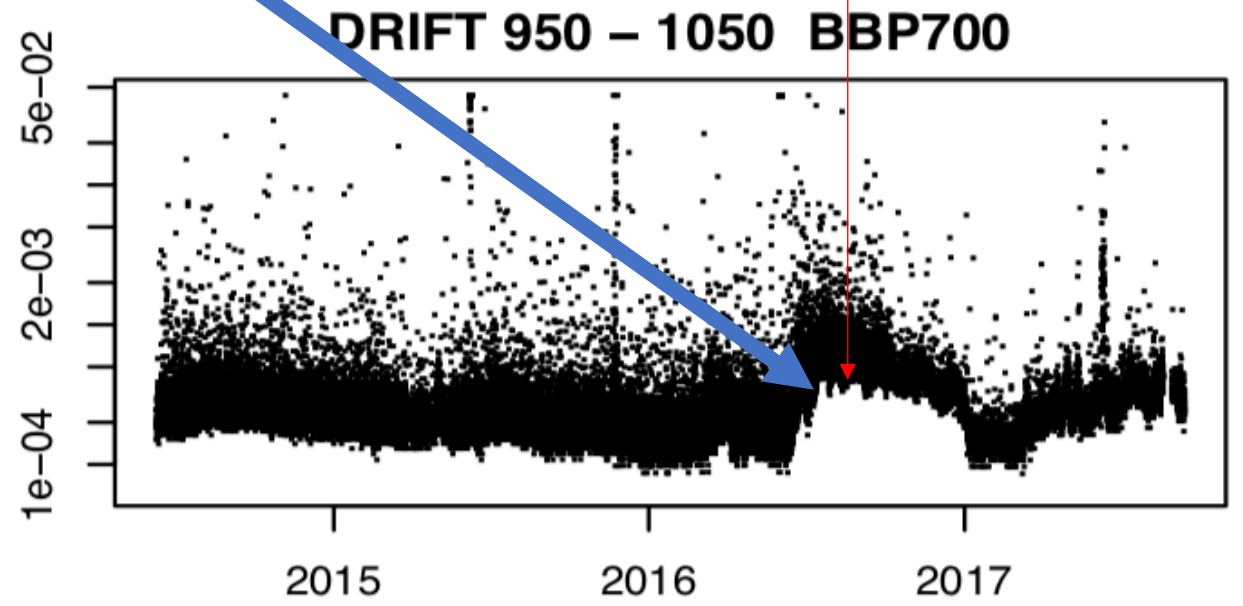
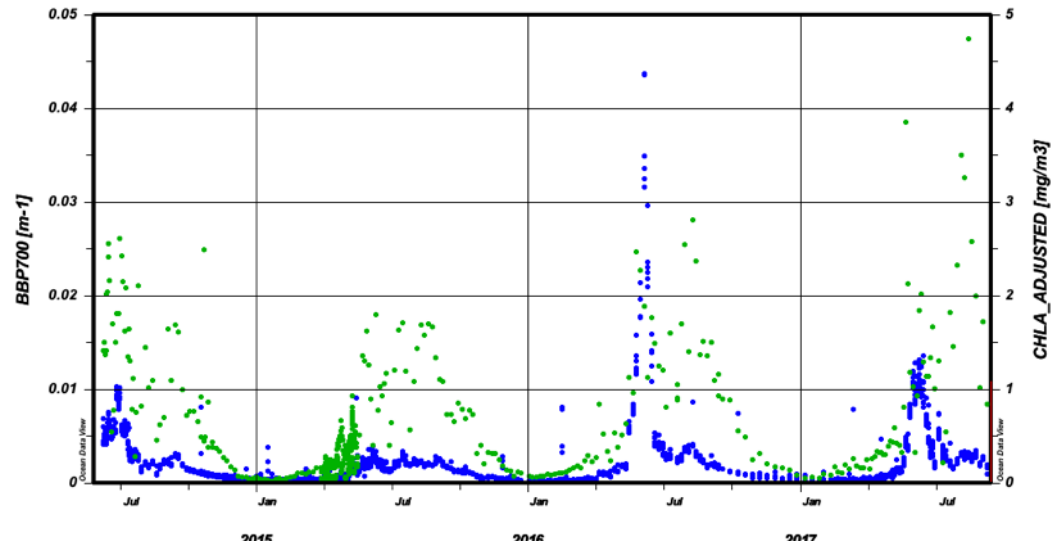
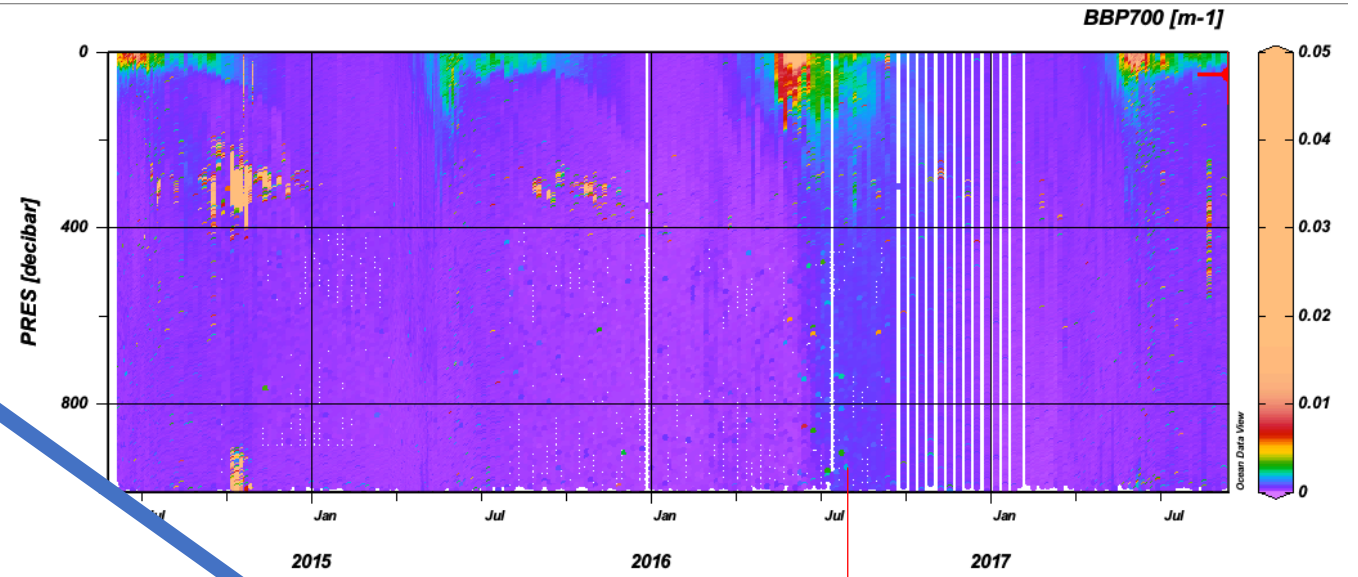
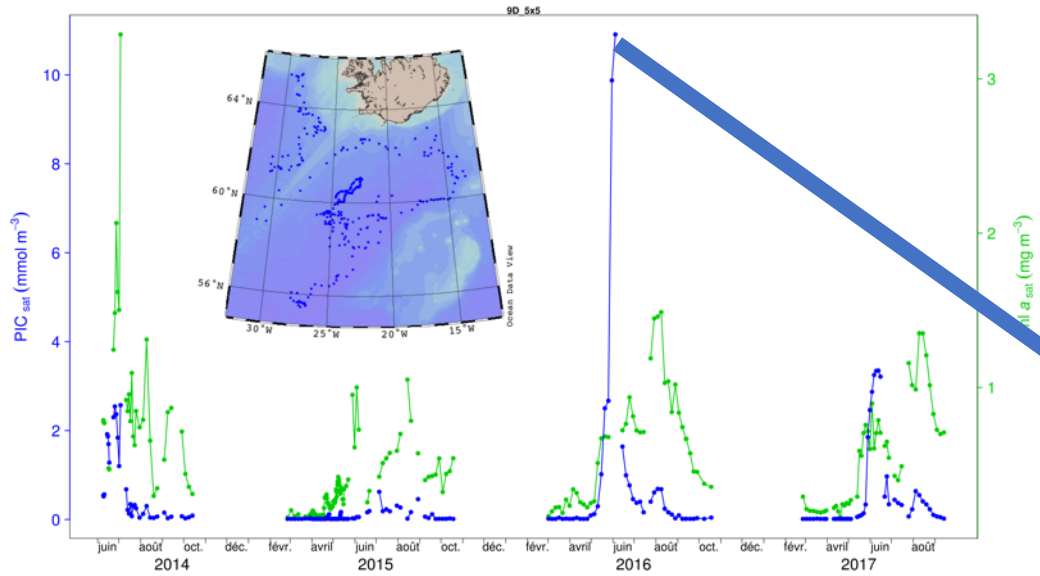

Radiometry

- Relation to ocean color = > Validation of bio-optical algorithms linking products (e.g. [Chl]) to optical properties (e.g. diffuse attenuation coefficient)
- Large datasets allowing to track regional “nuances” in these datasets (e.g. CDOM vs Chla)
- Allow for better constraining the calibration slope (Fchla vs [Chla]) of fluorometers

A Novel Near-Real-Time Quality-Control Procedure for Radiometric Profiles Measured by Bio-Argo Floats: Protocols and Performances

EMANUELE ORGANELLI,* HERVÉ CLAUSTRE,* ANNICK BRICAUD,* CATHERINE SCHMECHTIG,+
ANTOINE POTEAU,* XIAOGANG XING,#,@ LOUIS PRIEUR,* FABRIZIO D'ORTENZIO,* GIORGIO
DALL'OLMO,&,** AND VINCENZO VELLUCCI*

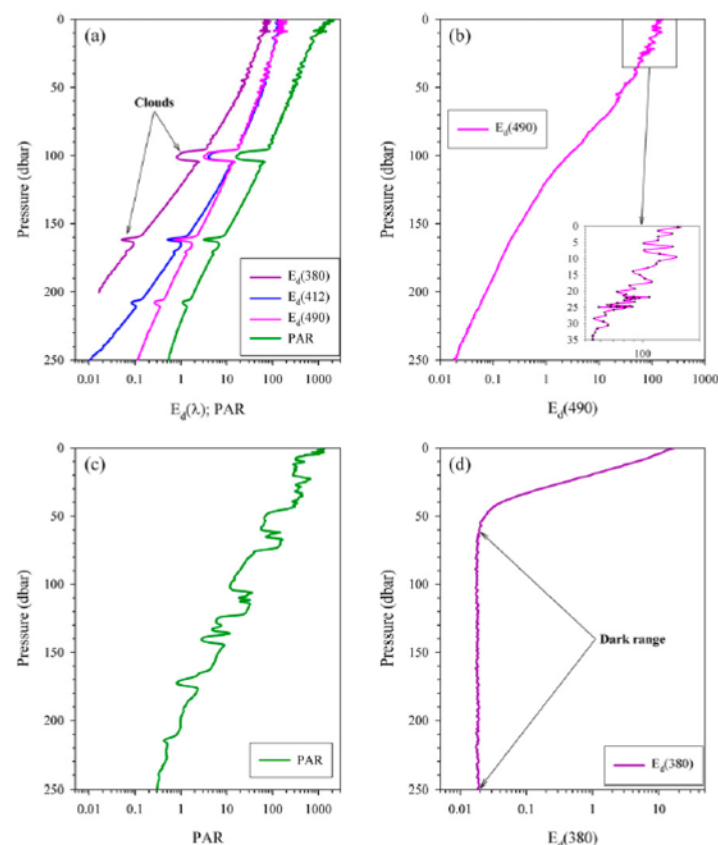

FIG. 3. Examples of (a) atmospheric cloud occurrence along profiles acquired by Bio-Argo floats (float WMO 6901439), (b) wave focusing in the surface layer (float WMO 6901655), (c) profile acquired in very unstable sky and sea conditions (float WMO 6901439), and (d) dark range occurrence along the profile (float WMO 6901486). Values of $E_d(\lambda)$ at 380, 412, and 490 nm are expressed as $\mu\text{W cm}^{-2} \text{nm}^{-1}$. PAR values are expressed as $\mu\text{mol quanta m}^{-2} \text{s}^{-1}$. Depth is expressed in units of pressure.

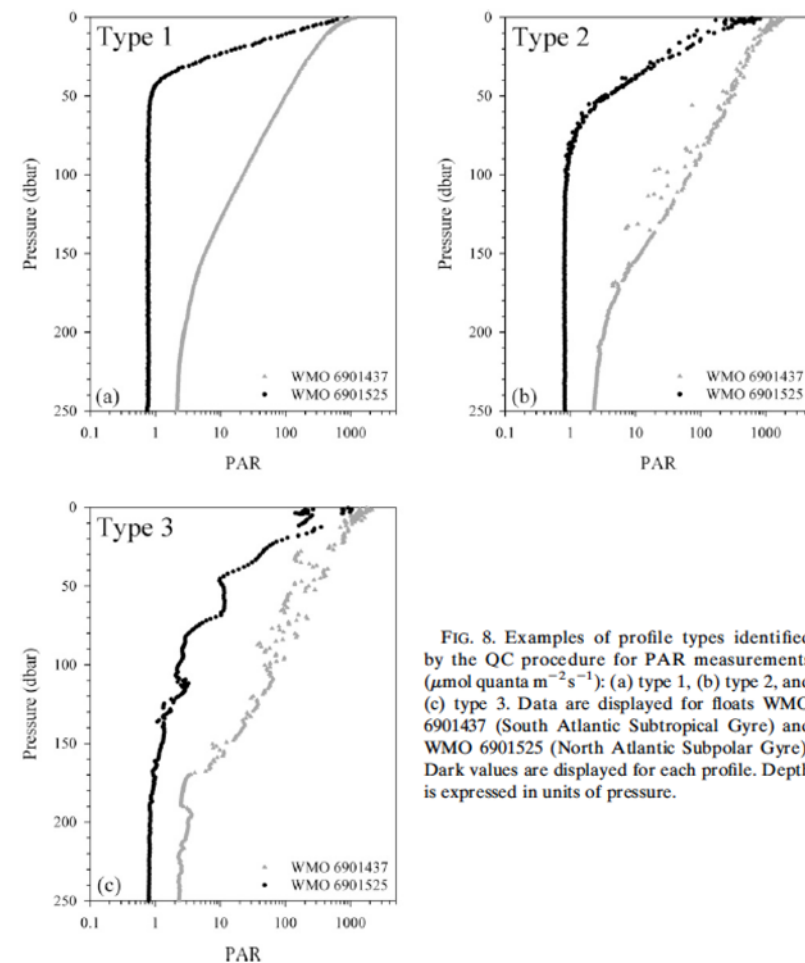

FIG. 8. Examples of profile types identified by the QC procedure for PAR measurements ($\mu\text{mol quanta m}^{-2} \text{s}^{-1}$): (a) type 1, (b) type 2, and (c) type 3. Data are displayed for floats WMO 6901437 (South Atlantic Subtropical Gyre) and WMO 6901525 (North Atlantic Subpolar Gyre). Dark values are displayed for each profile. Depth is expressed in units of pressure.

RESEARCH ARTICLE

10.1002/2016JC012629

Key Points:

- Different optical behaviors among oceanic regions as observed from diffuse attenuation coefficients within the first optical depth
- High content of colored dissolved organic matter causes the deviation of most open ocean waters from existing bio-optical models

Bio-optical anomalies in the world's oceans: An investigation on the diffuse attenuation coefficients for downward irradiance derived from Biogeochemical Argo float measurements

Emanuele Organelli^{1,2}, Hervé Claustre¹, Annick Bricaud¹, Marie Barbieux¹, Julia Uitz¹, Fabrizio D'Ortenzio¹, and Giorgio Dall'Olmo^{2,3}

¹Sorbonne Universités, UPMC Univ Paris 06, CNRS, UMR 7093, Laboratoire d'Océanographie de Villefranche (LOV), Villefranche-sur-mer, France, ²Plymouth Marine Laboratory, Plymouth, UK, ³National Centre for Earth Observation, Plymouth Marine Laboratory, Plymouth, UK

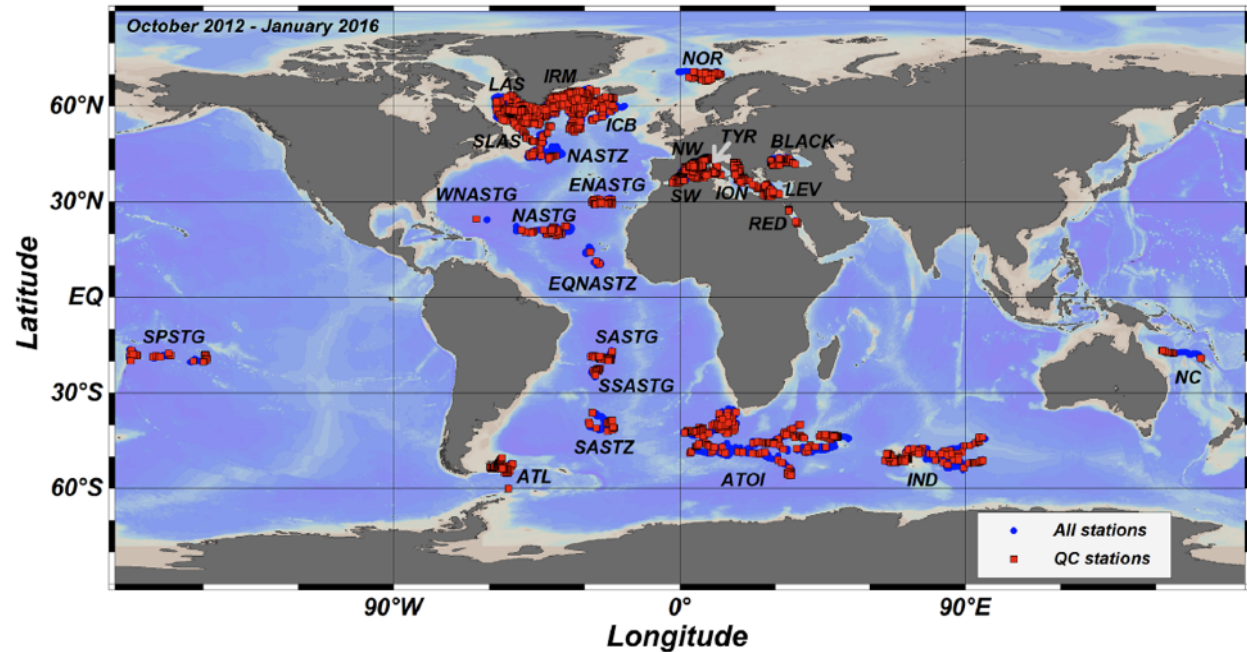

Radiometry: Nonanomalous and anomalous regions as compared to the global ocean

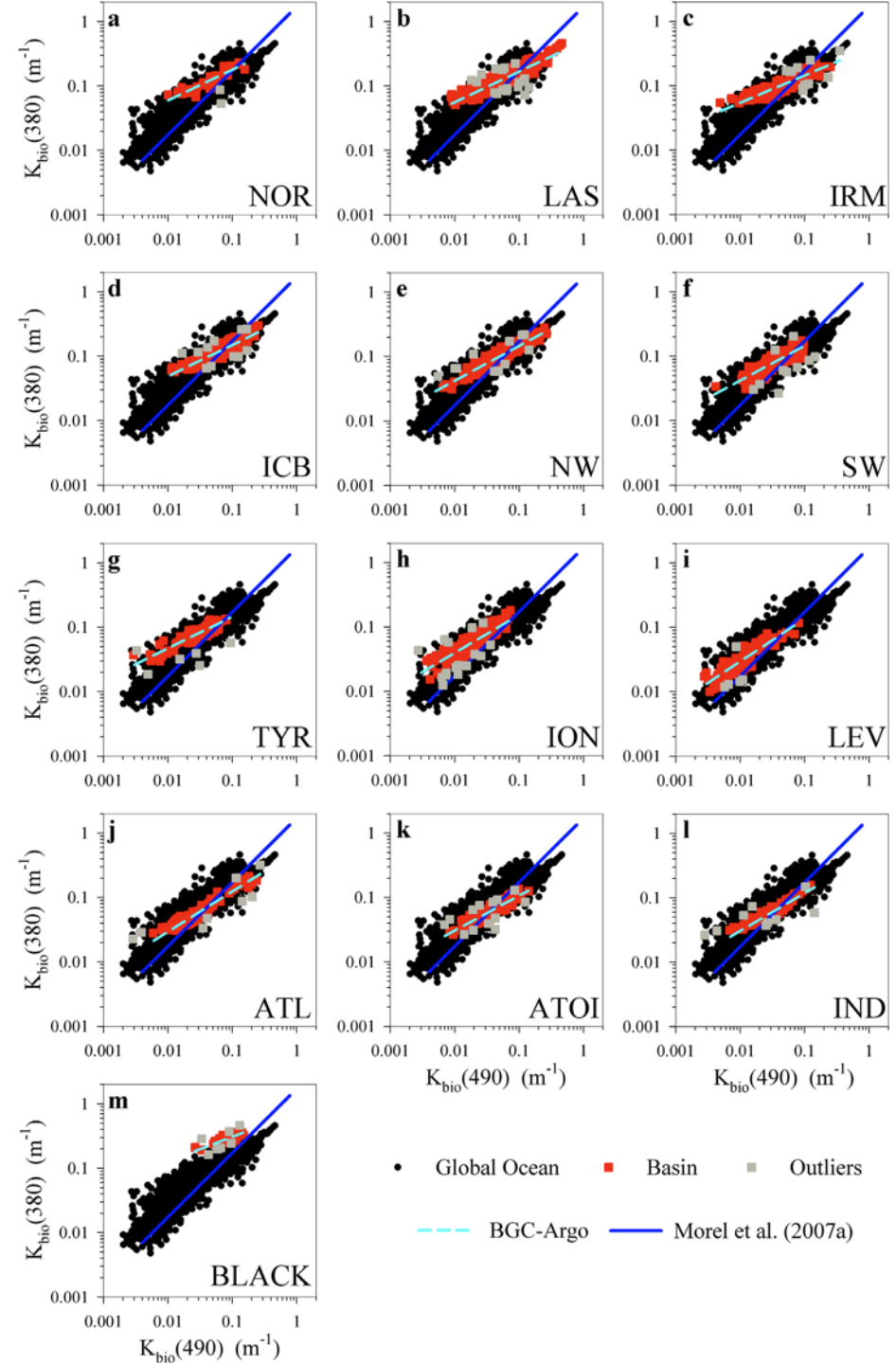
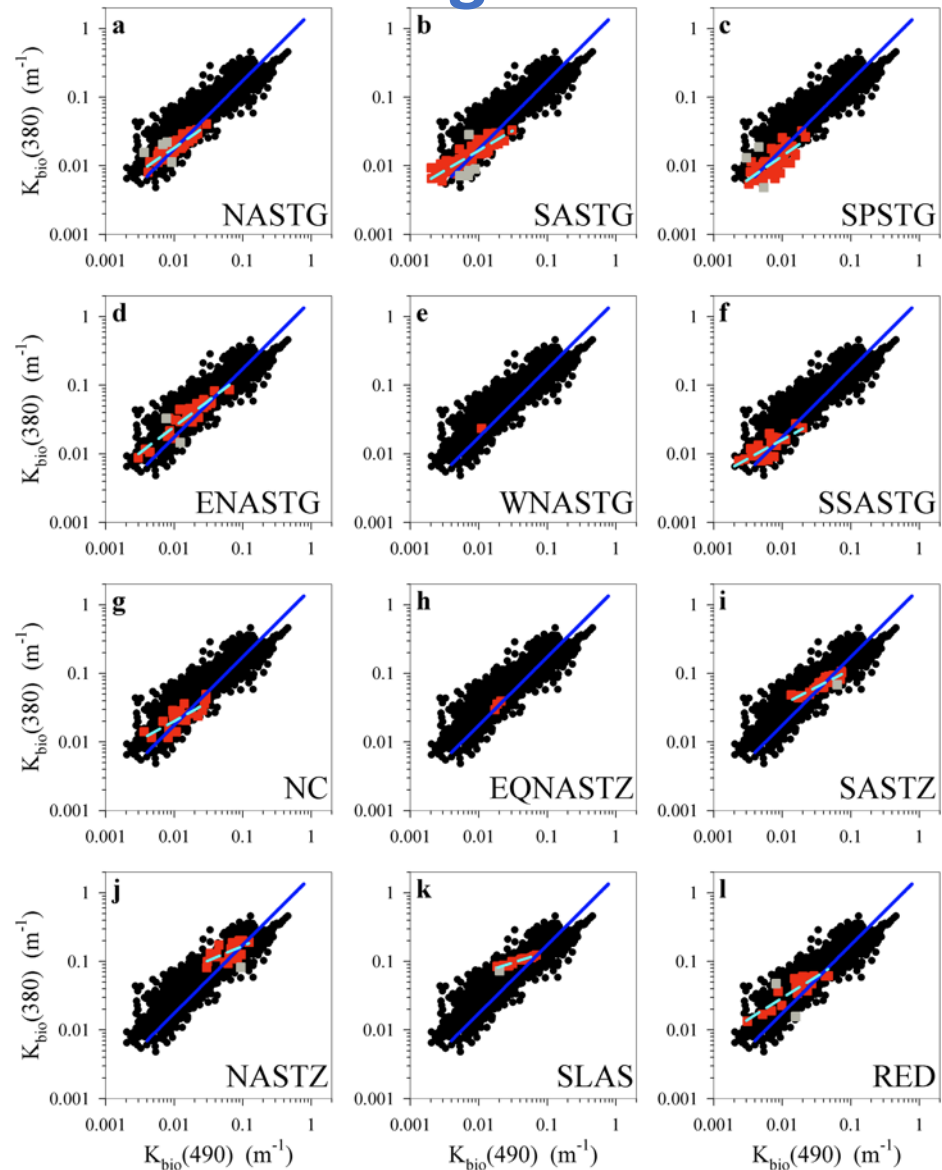

• Global Ocean ■ Basin ■ Outliers - - - BGC-Argo — Morel et al. (2007a)

• Global Ocean ■ Basin ■ Outliers
- - - BGC-Argo — Morel et al. (2007a)

High vertical resolution : from noise and spikes to proxies

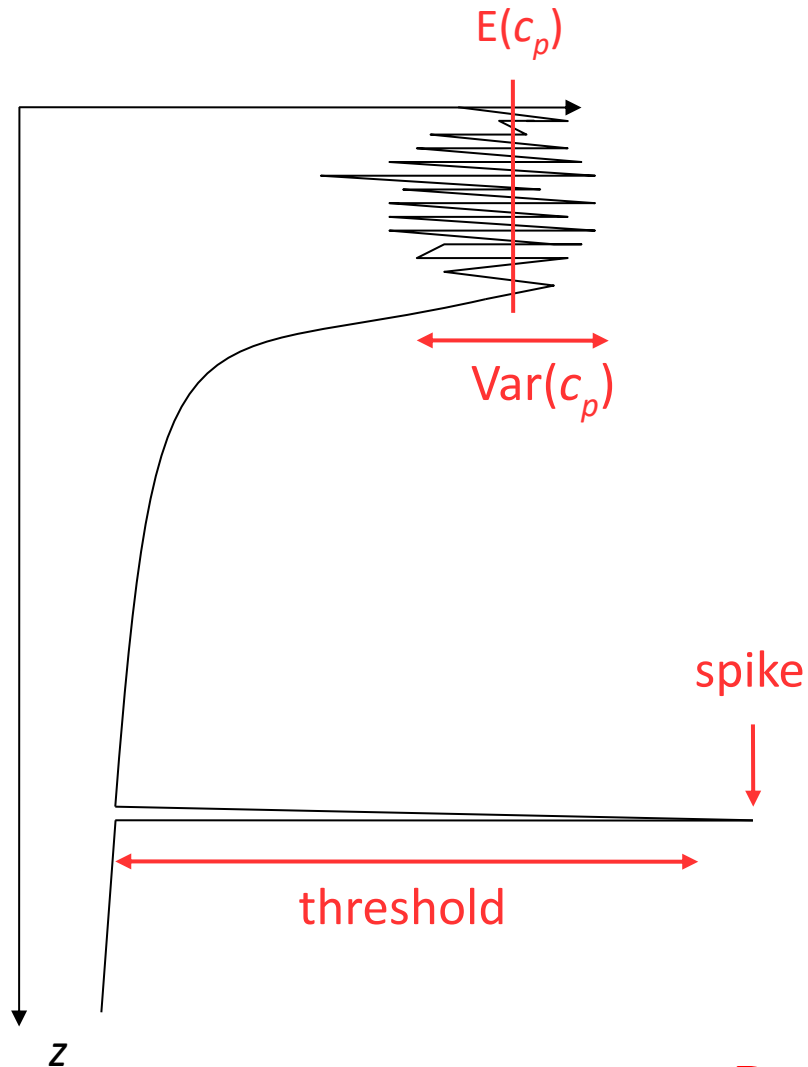

Particle diameter in the mixed layer

$$d_{ML} \sim \text{Var}(c_p) / E(c_p)$$

(Briggs et al. 2013)

Particle export in the mesopelagic

Spike when

signal - baseline > threshold

(Briggs et al. 2011)

**Importance of adaptive sampling :
Depth resolution, tuneable thanks to iridium**

High vertical resolution (spikes) : sinking of large particles / agregates: Differences on each side of Kerguelen plateau

West
Iron-
limited

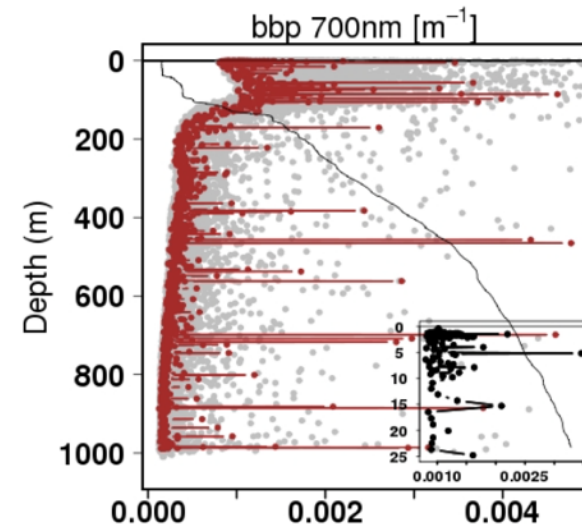
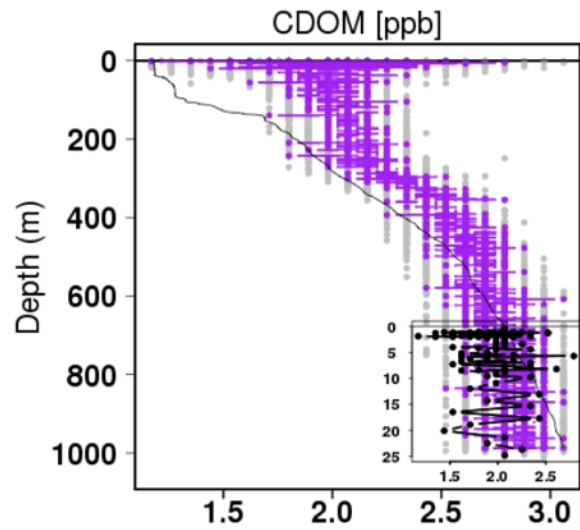
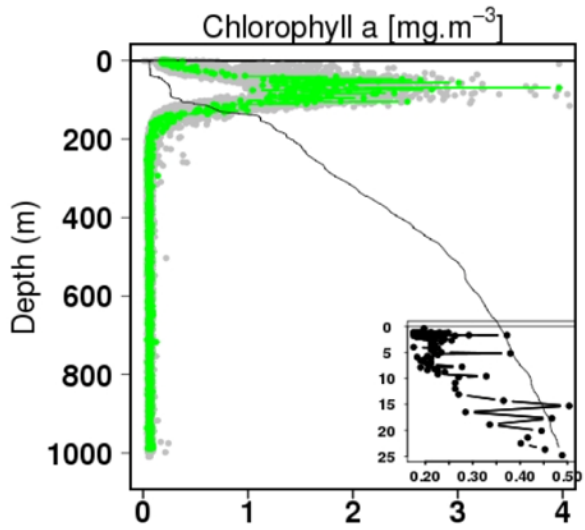

East:
Non-
limited

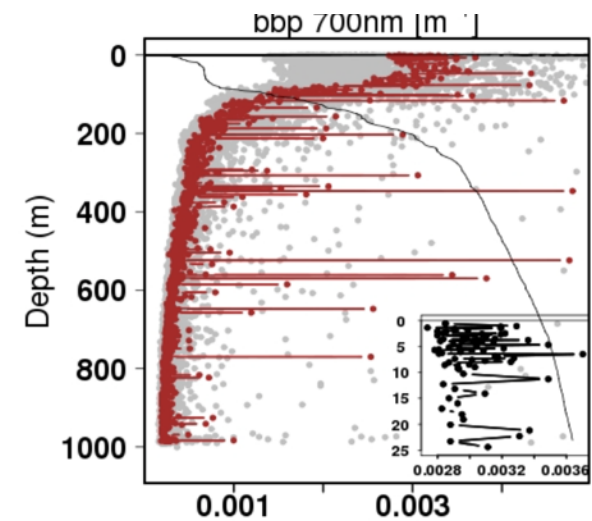
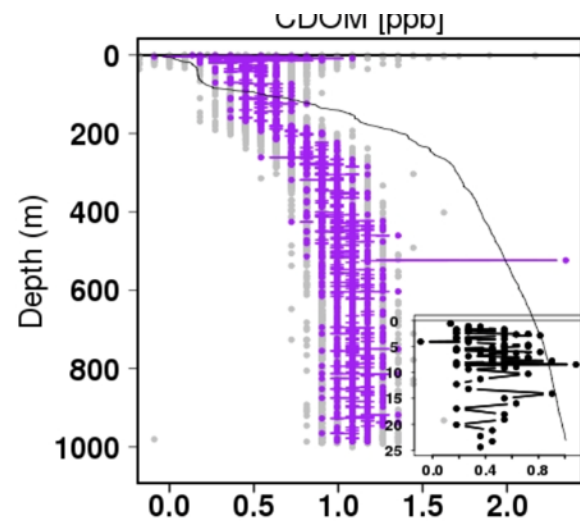
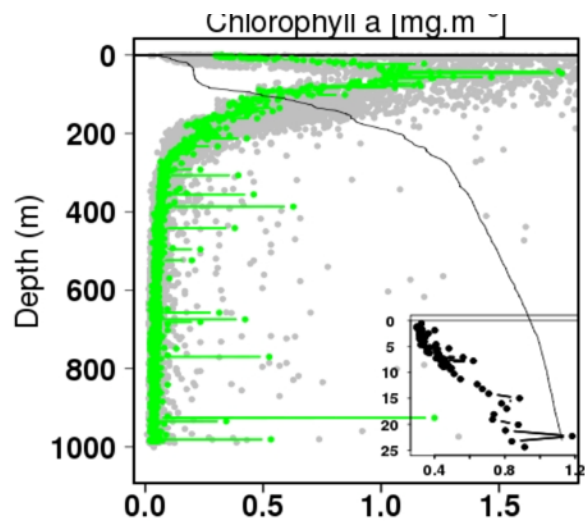

High vertical resolution (spikes)

50% of aggregates are « lost » in the mesopelagic by fragmentation

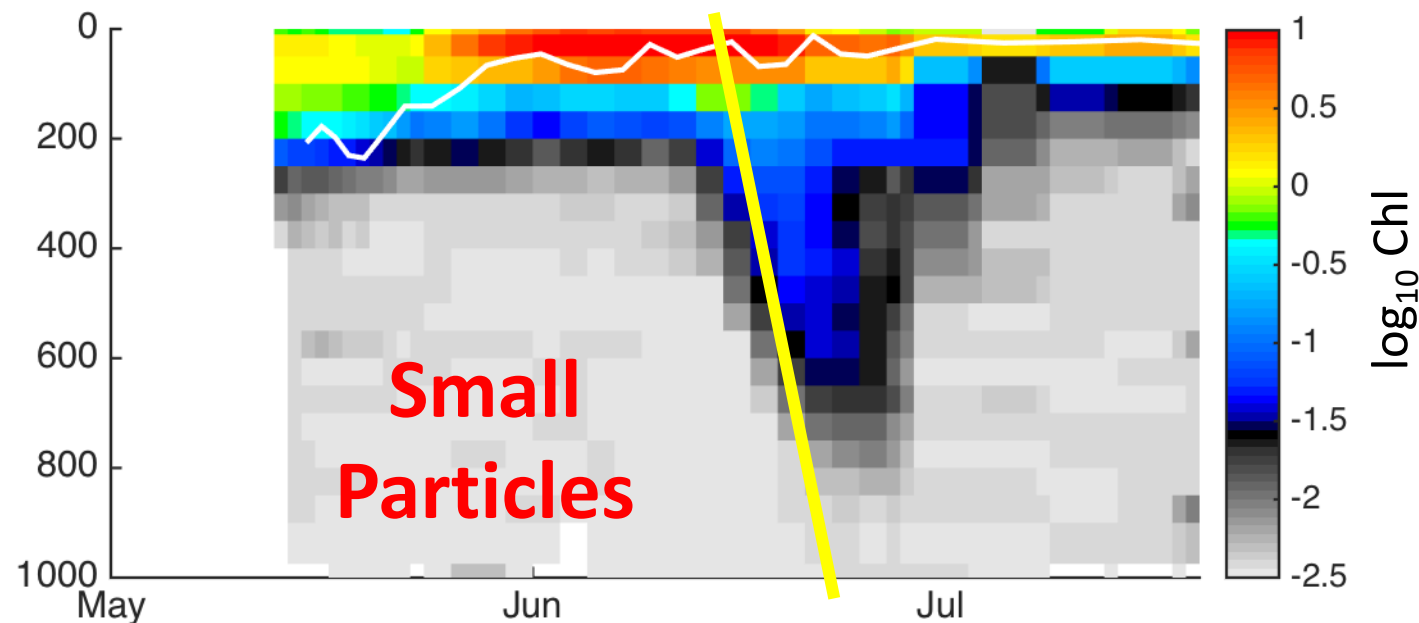
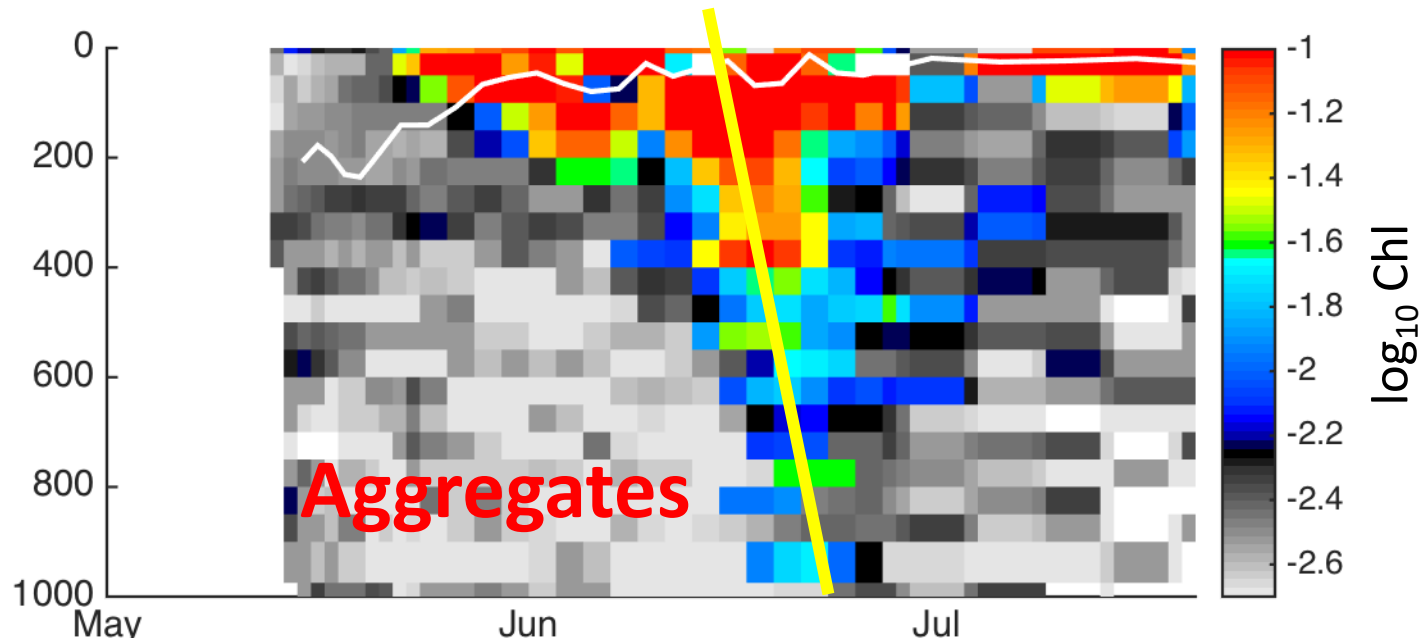
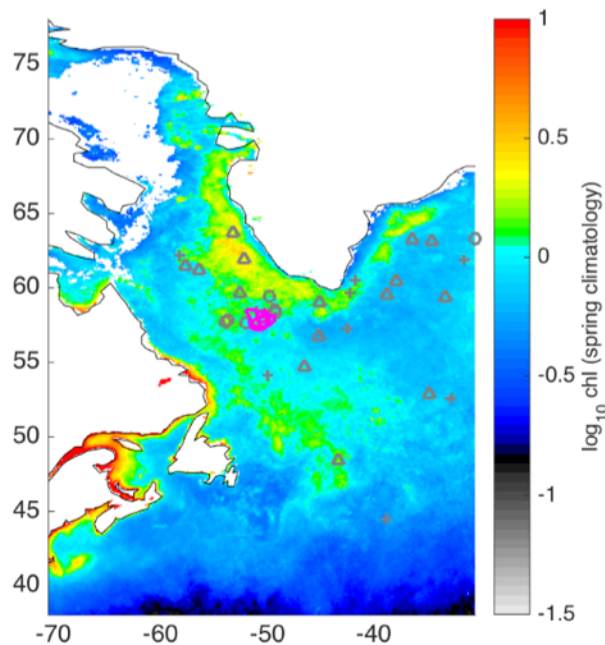

Briggs, Dall'Olmo & Claustre (2020):
Major role of particle fragmentation
in regulating biological sequestration
of CO₂ by the oceans. *Science*, in
press

High vertical resolution (noise): size at surface impacts on export at depth

Near-surface predictors of deep sinking particle concentrations

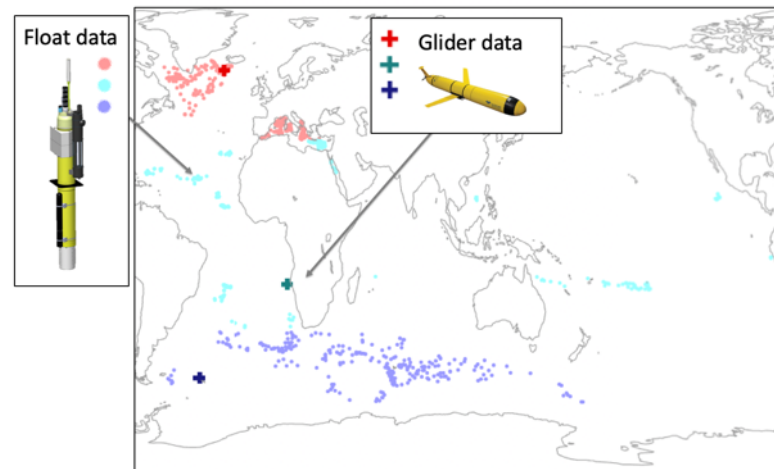
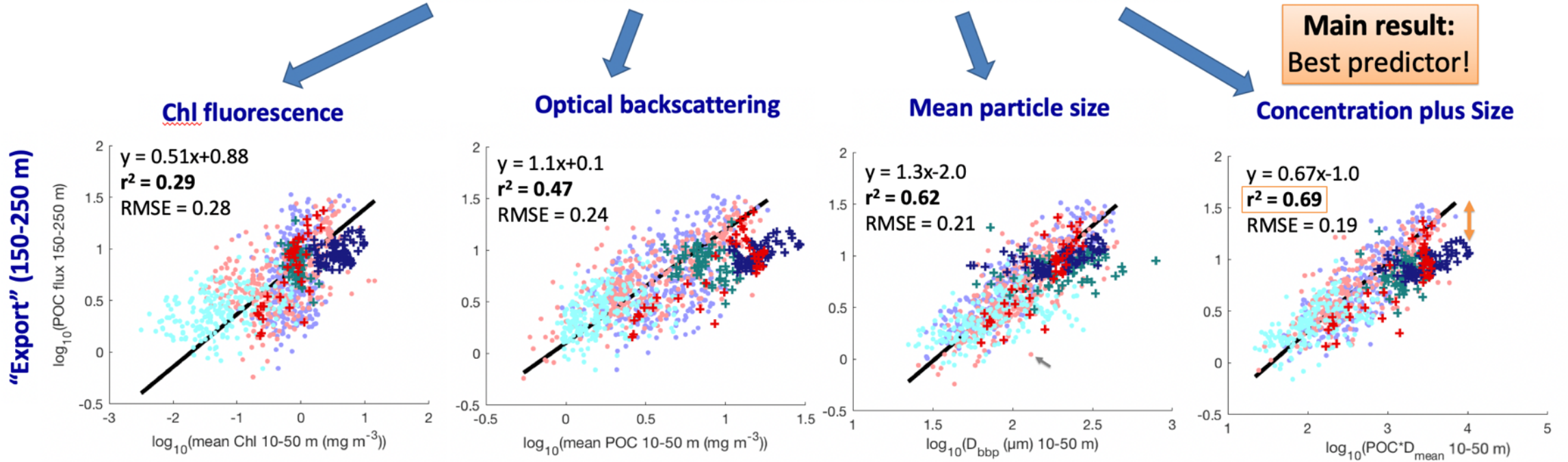

The mechanisms of export from surface to the mesopelagic domain (Biological Carbon Pump) are potentially multiple : we need to reconsider the classical paradigm of the “gravitational pump”

- Particle Injection Pumps (PIPs) also contribute delivering POC and DOC at depth:
 - Physically mediated pumps
 - Subduction (at various scale)
 - Mixed layer (seasonal, event)
 - Biologically mediated pumps
 - Diel migration
 - Seasonal migration
- **BGC-Argo could become an essential network for understanding and quantifying these mechanisms.**

REVIEW

<https://doi.org/10.1038/s41586-019-1098-2>

Multi-faceted particle pumps drive carbon sequestration in the ocean

Philip W. Boyd^{1*}, Hervé Claustre^{2,6}, Marina Levy^{3,6}, David A. Siegel^{4,6} & Thomas Weber^{5,6}

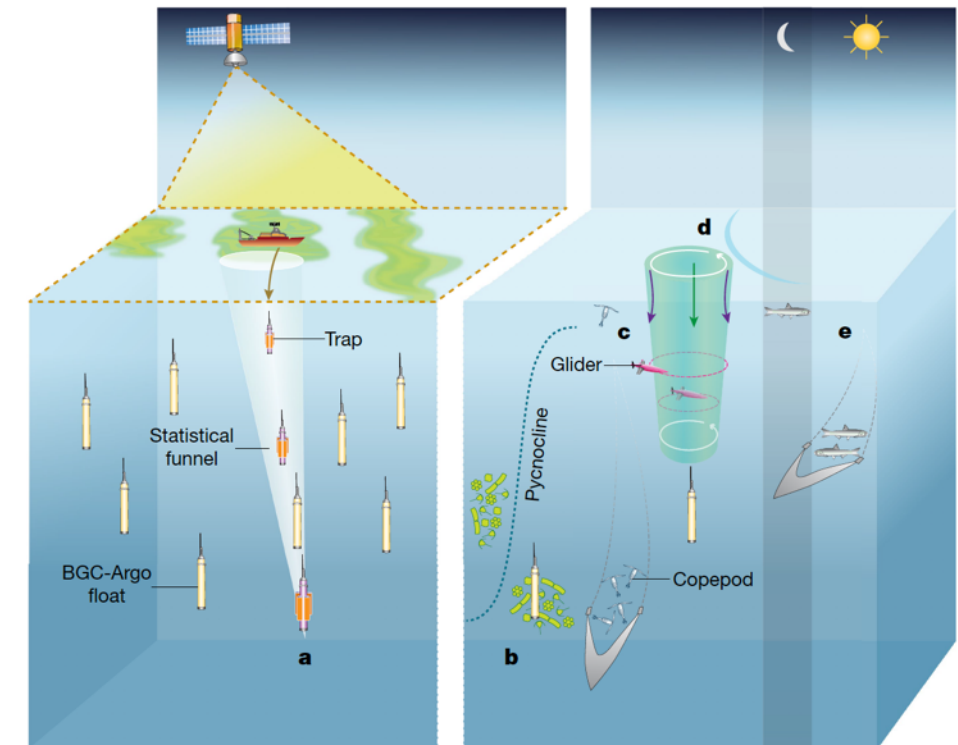

RESEARCH ARTICLE
10.1029/2018GB005997

The Intraseasonal Dynamics of the Mixed Layer Pump in the Subpolar North Atlantic Ocean: A Biogeochemical-Argo Float Approach

L. Lacour^{1,2}, N. Briggs³, H. Claustre¹, M. Ardyna^{1,4}, and G. Dall'Olmo^{5,6}

RESEARCH ARTICLE
10.1002/2017JC012861

Evaluating Southern Ocean Carbon Eddy-Pump From Biogeochemical-Argo Floats

Joan Llorc^{1,2,3}, C. Langlais³, R. Matear^{2,3}, S. Moreau^{1,4}, A. Lenton^{3,5}, and Peter G. Strutton^{1,2,3}

Special Section:
The Southern Ocean Carbon and Climate Observations and Modelling (SOCCOM)

Key Points:
• The density of BGC-Argo float network enables identification of episodic mixed layer pump events

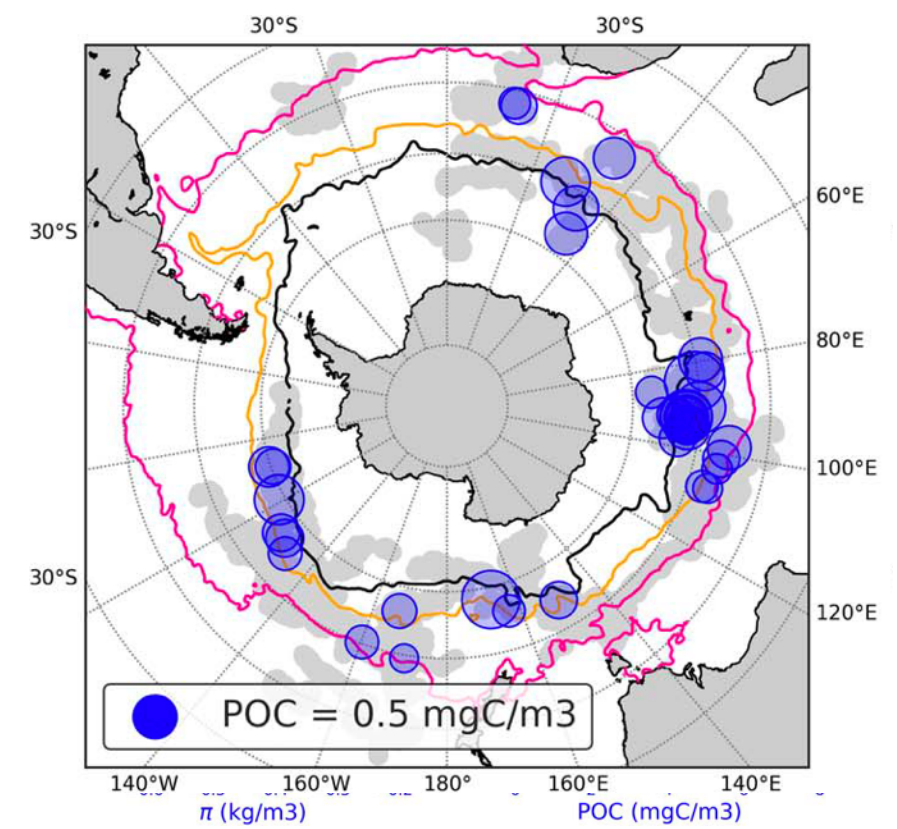
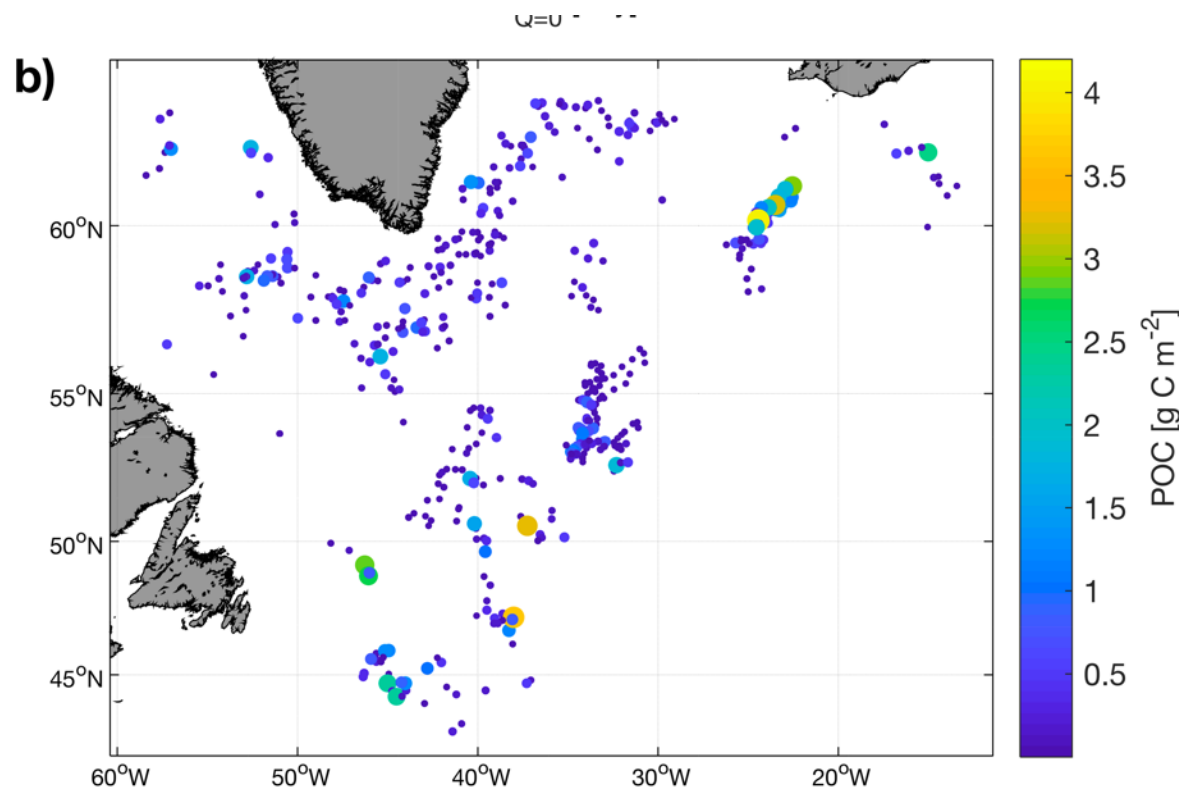

Converting the TZ signature of PIPs into fluxes requires additional assumption / constraints (MLP: time elapsed since the last mixing event, ESP : advective velocities) => uncertainties

Float-based evidences of mesopelagic organisms migration

Icelandic Basin, end of October

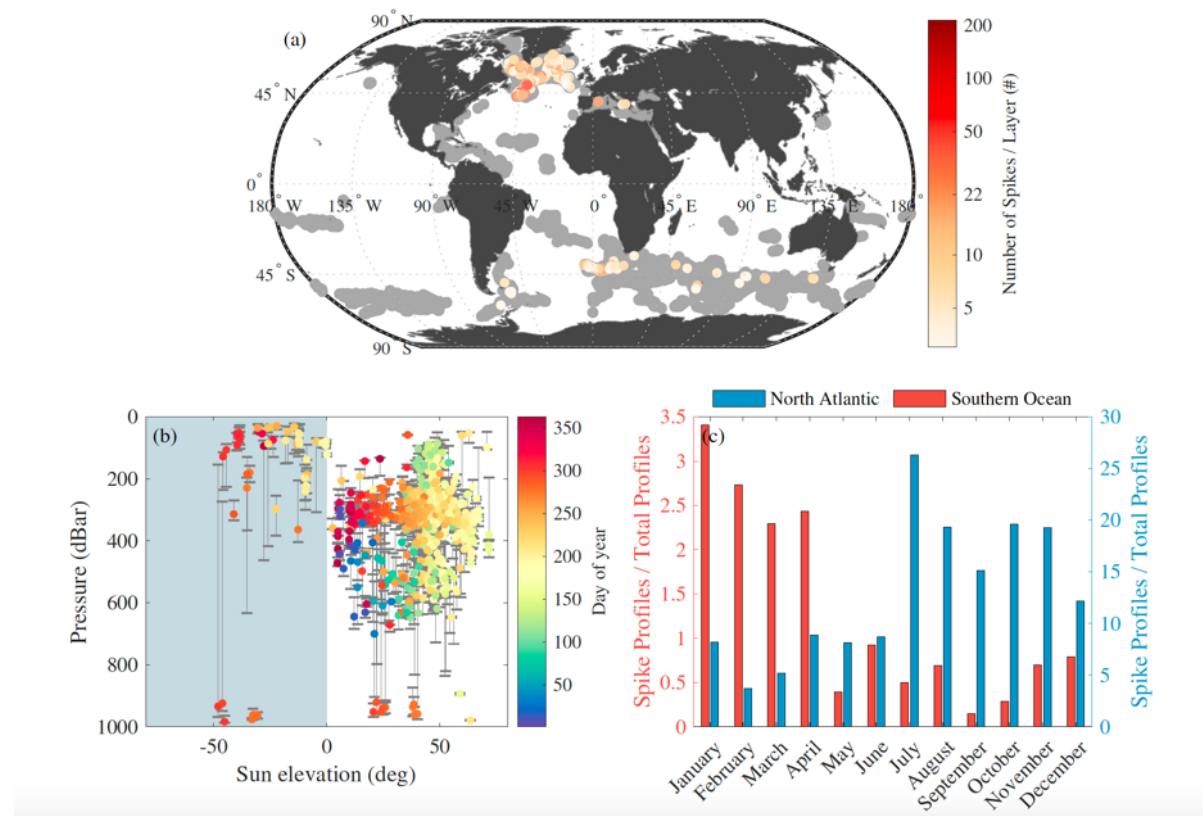
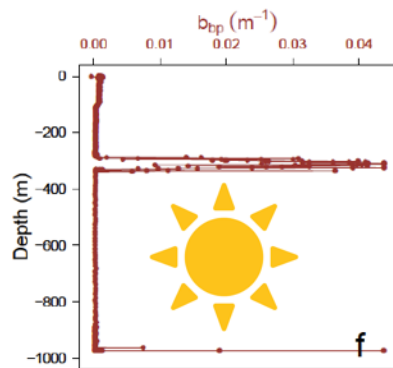
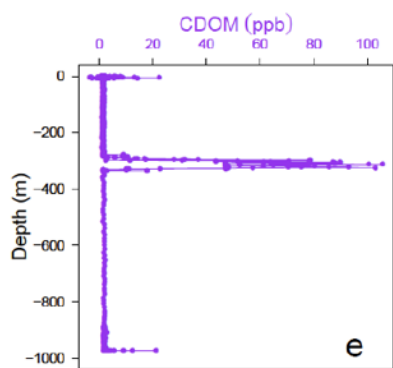
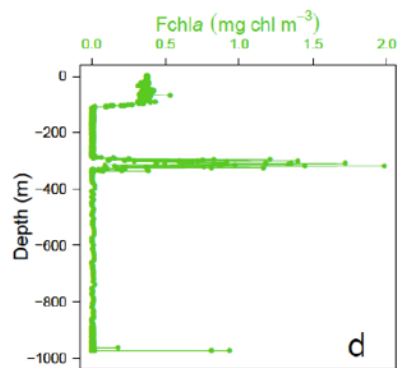
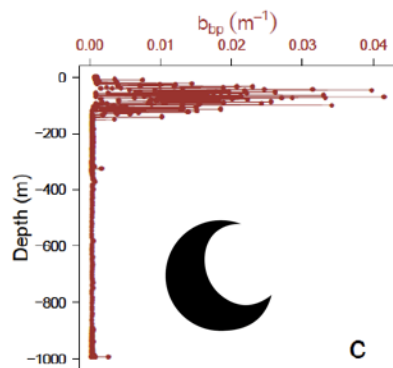
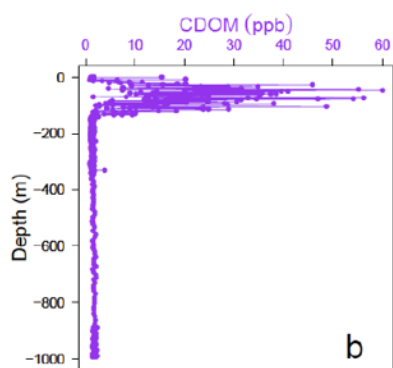
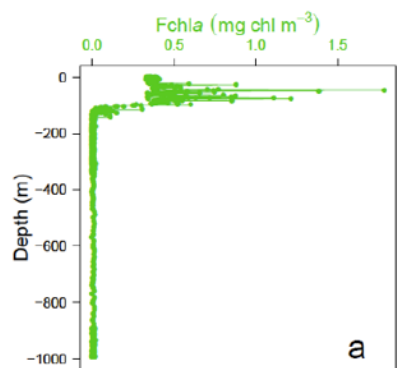
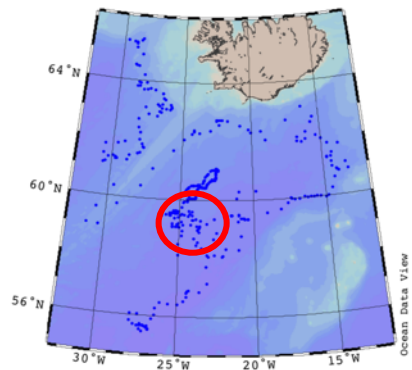

From Boyd et al. (supplementary), 2019

Haentjen et al., in review

The under-water vision profiler particle sizing & « onboard » image analysis

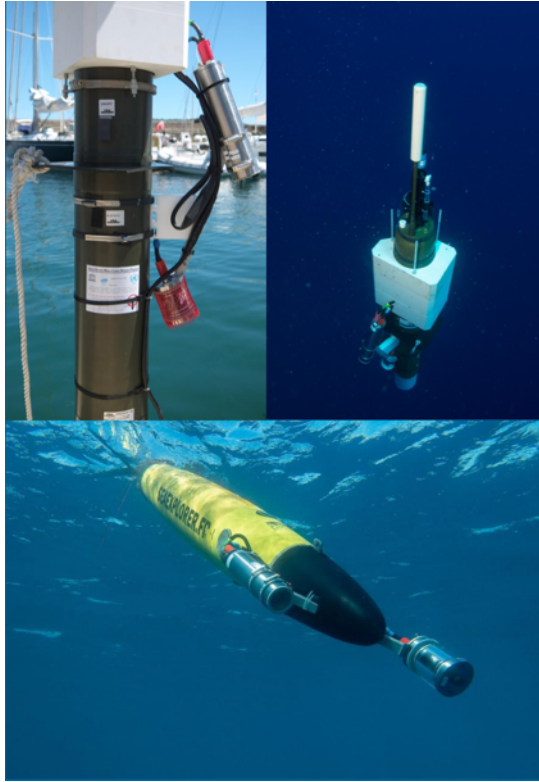

- 2.6 kg in air, 1.6 kg in water
- Depth rating: 6000m
- Collimated illumination in the red
- Intelligent camera
- Size : 100 μm to 1 cm
- Volume sampled: 0.6 L
- 1 W at 1.5 Hz max

Ascent / 22 Jun 2019 02:36 UT / lovapm015b_4279_059_01_C
 Jpeg created on Fri Jun 28 12:46:09 2019 with data processed on Fri Jun 28 12:45:52 2019 (Lon:7.47deg, Lat:43.53deg.)

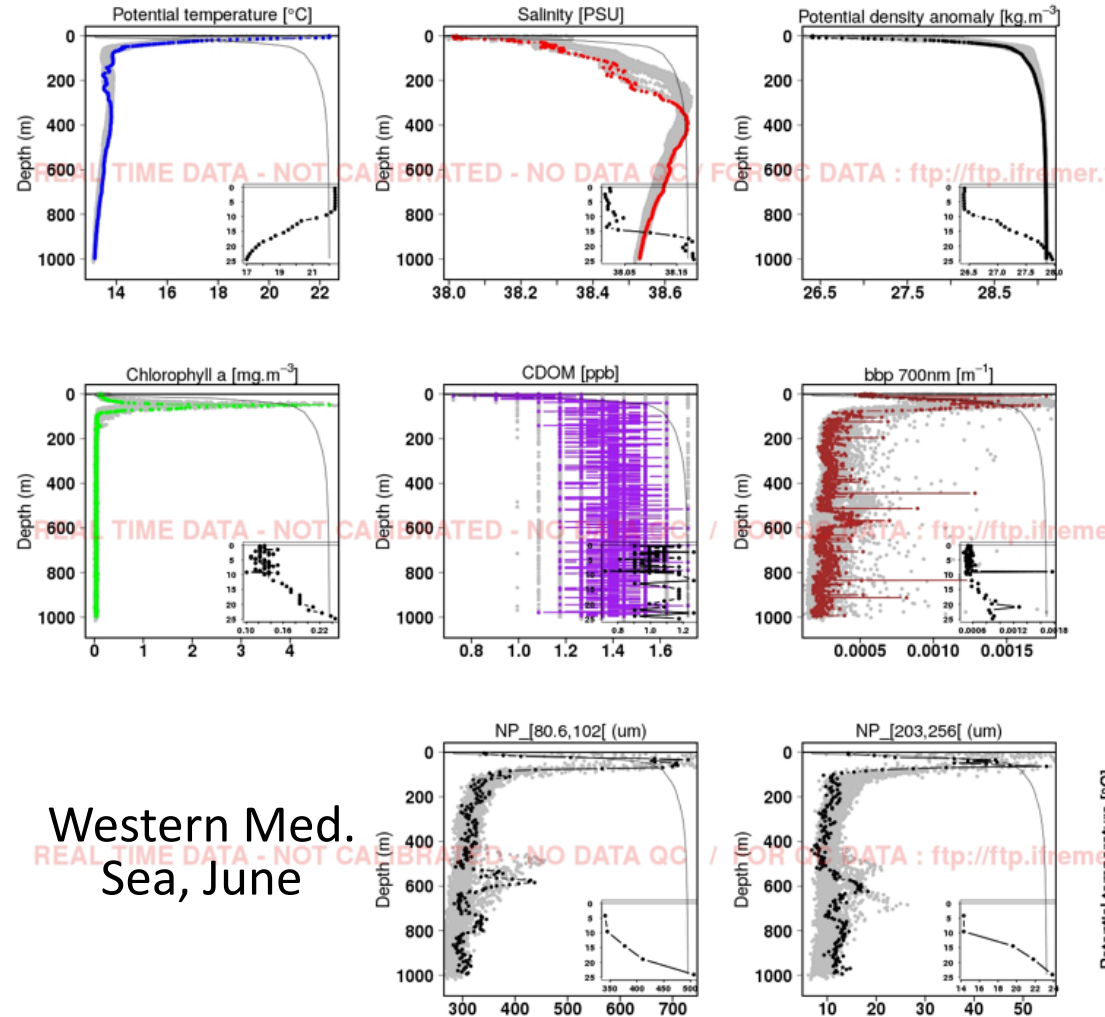

Western Med.
Sea, June

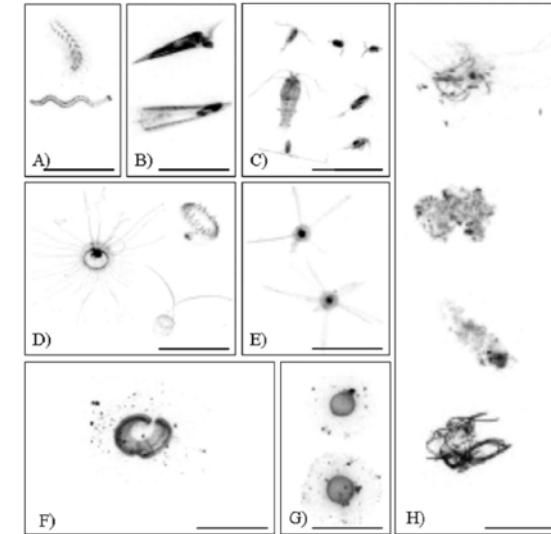

Active μ -sonar: collaboration with M. Johnson & P. Goulet, Sea Mammal Research Unit):



Sous l'égide de la Fondation de France



CENTRE NATIONAL D'ÉTUDES SPATIALES

GPS tracks from 2018 DTAGs

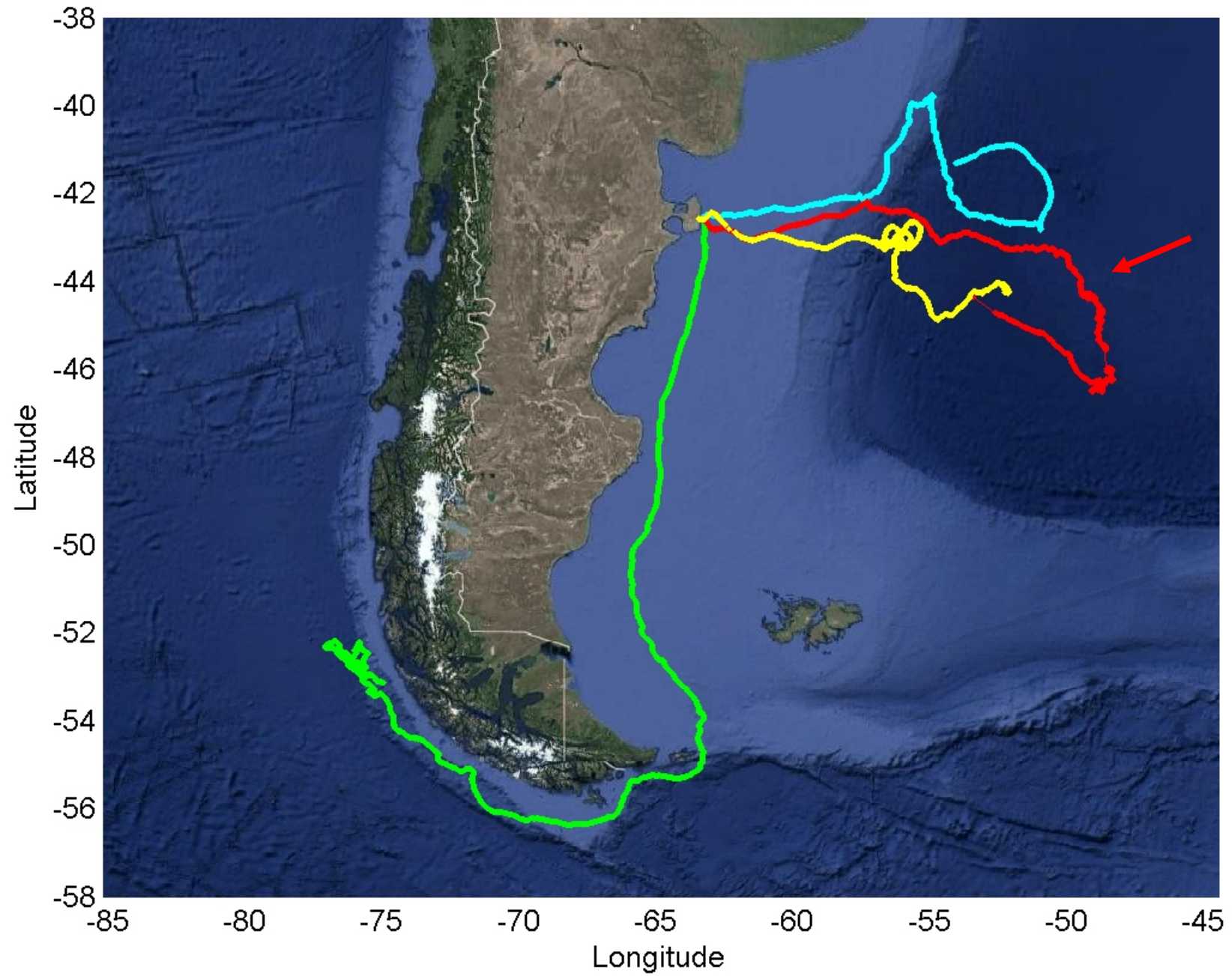

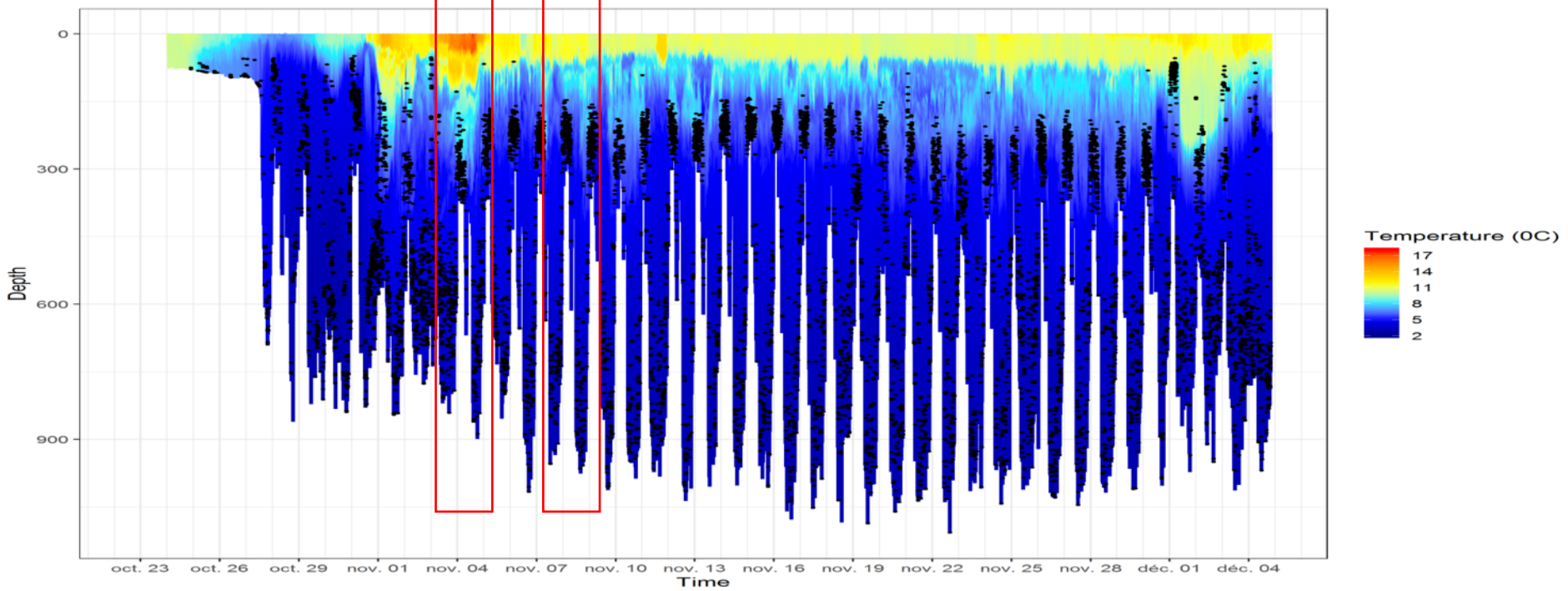
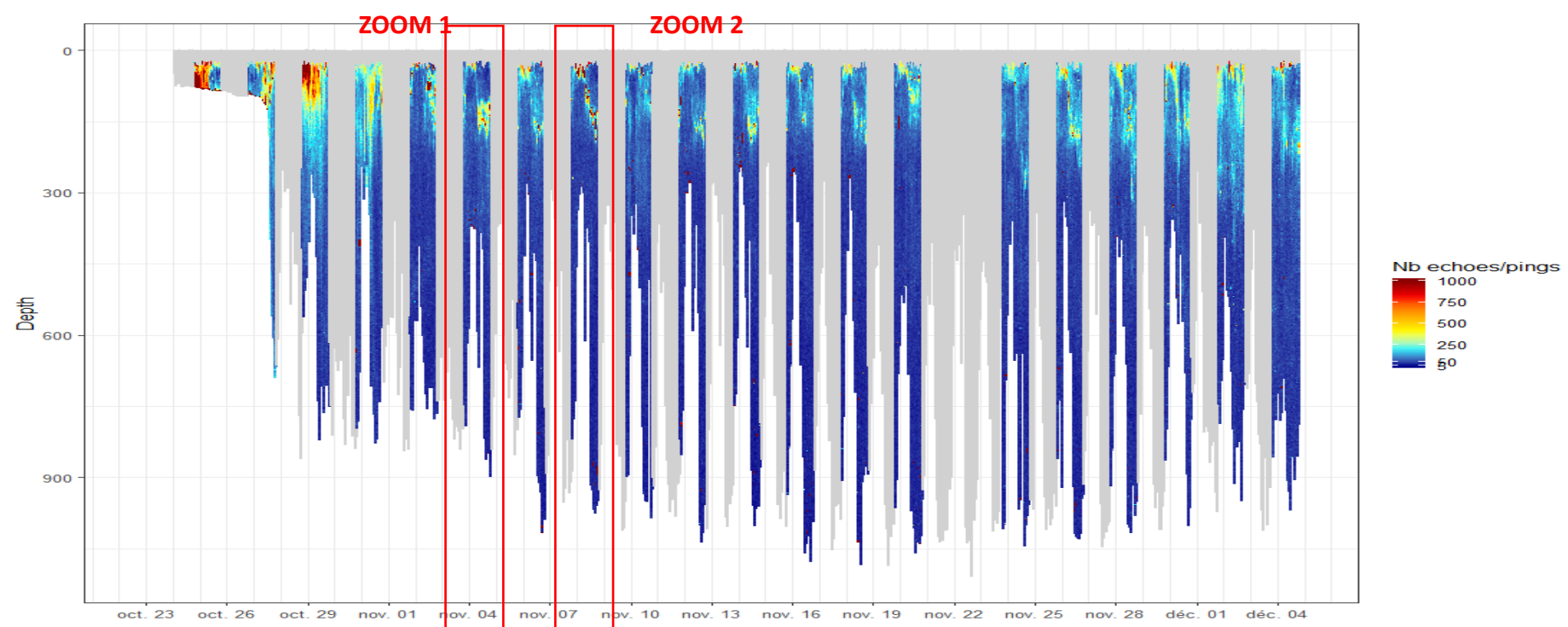

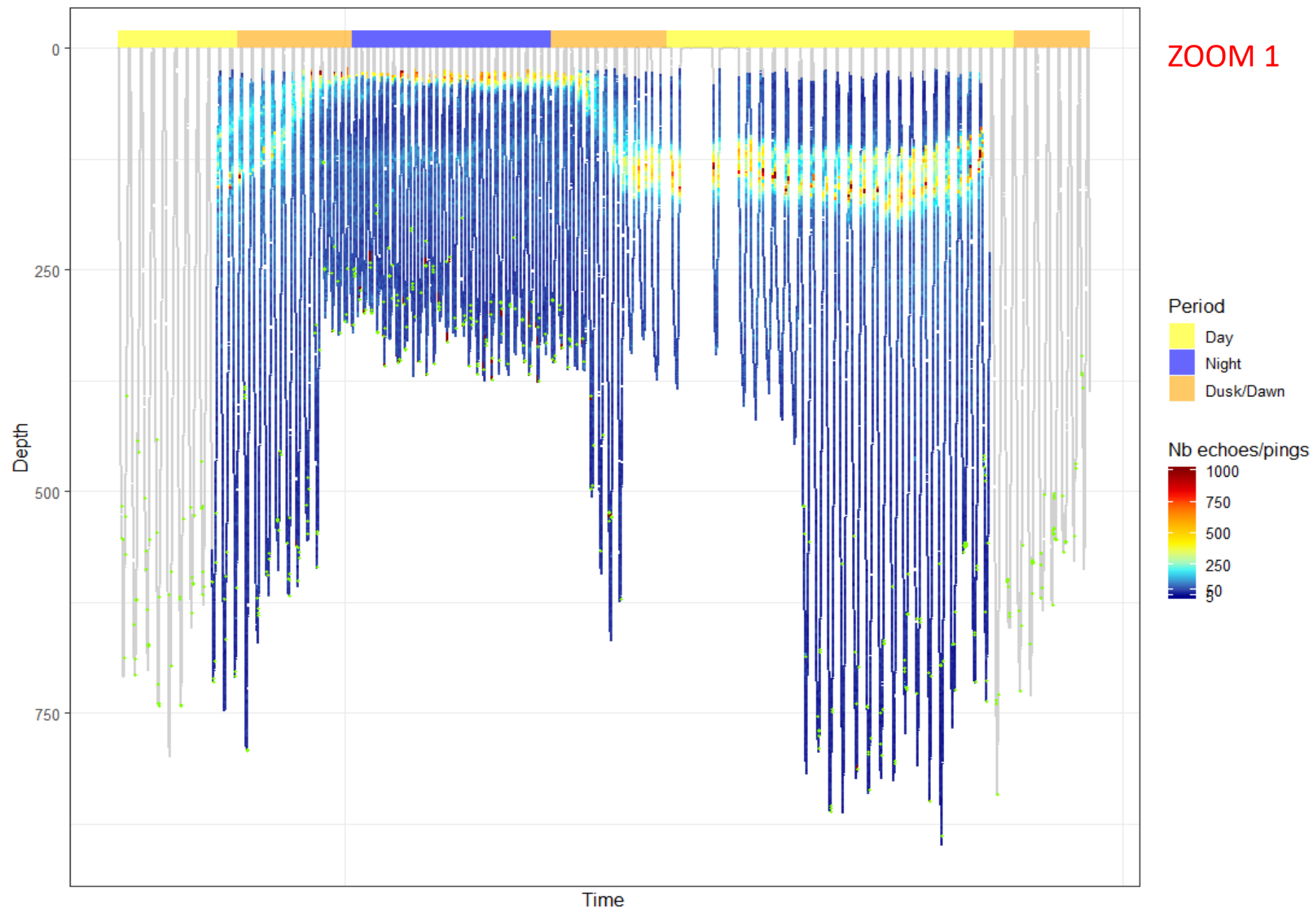



REFINE: Robotic Exploration of plankton-driven Flux in the marine twilight zone)

2020-2025



European Research Council

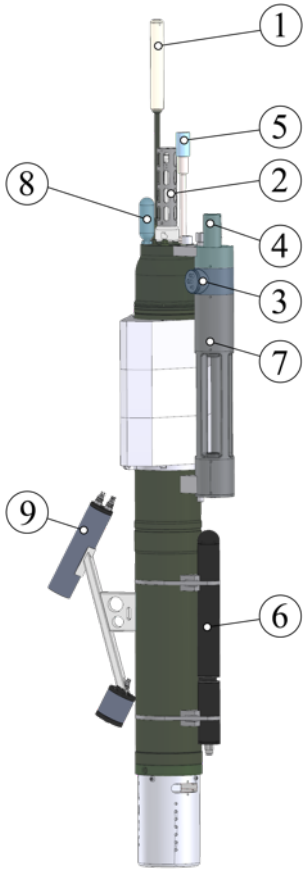

New floats

Technology

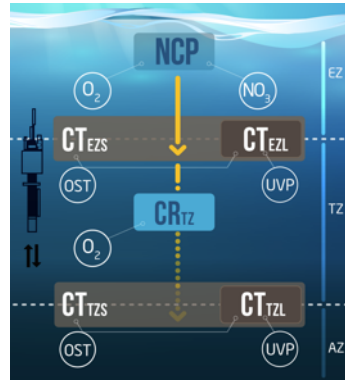

Budget of carbon export in...

...five key locations

Process studies

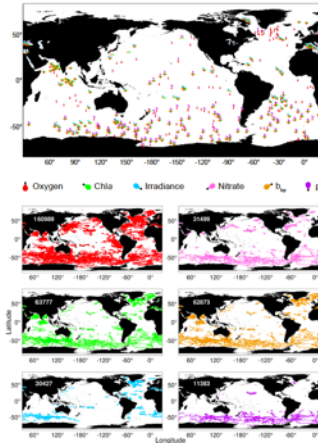

Argo, BGC-Argo

Satellite, reanalysis

Evaluate predictors of carbon export

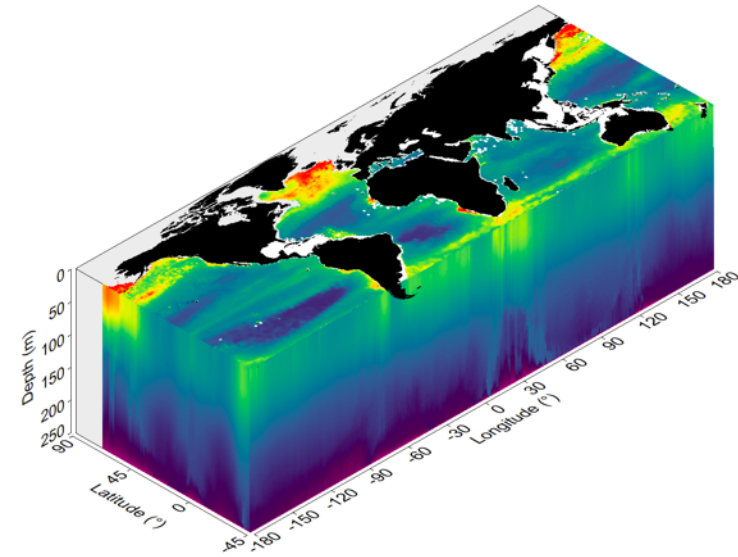
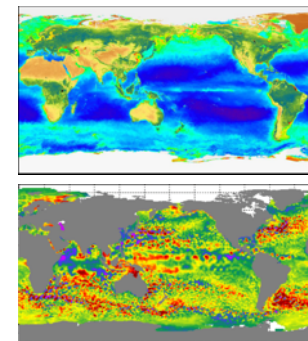

Upscaling carbon export



On the Future of Argo: A *Global, Full-Depth, Multi-Disciplinary Array*

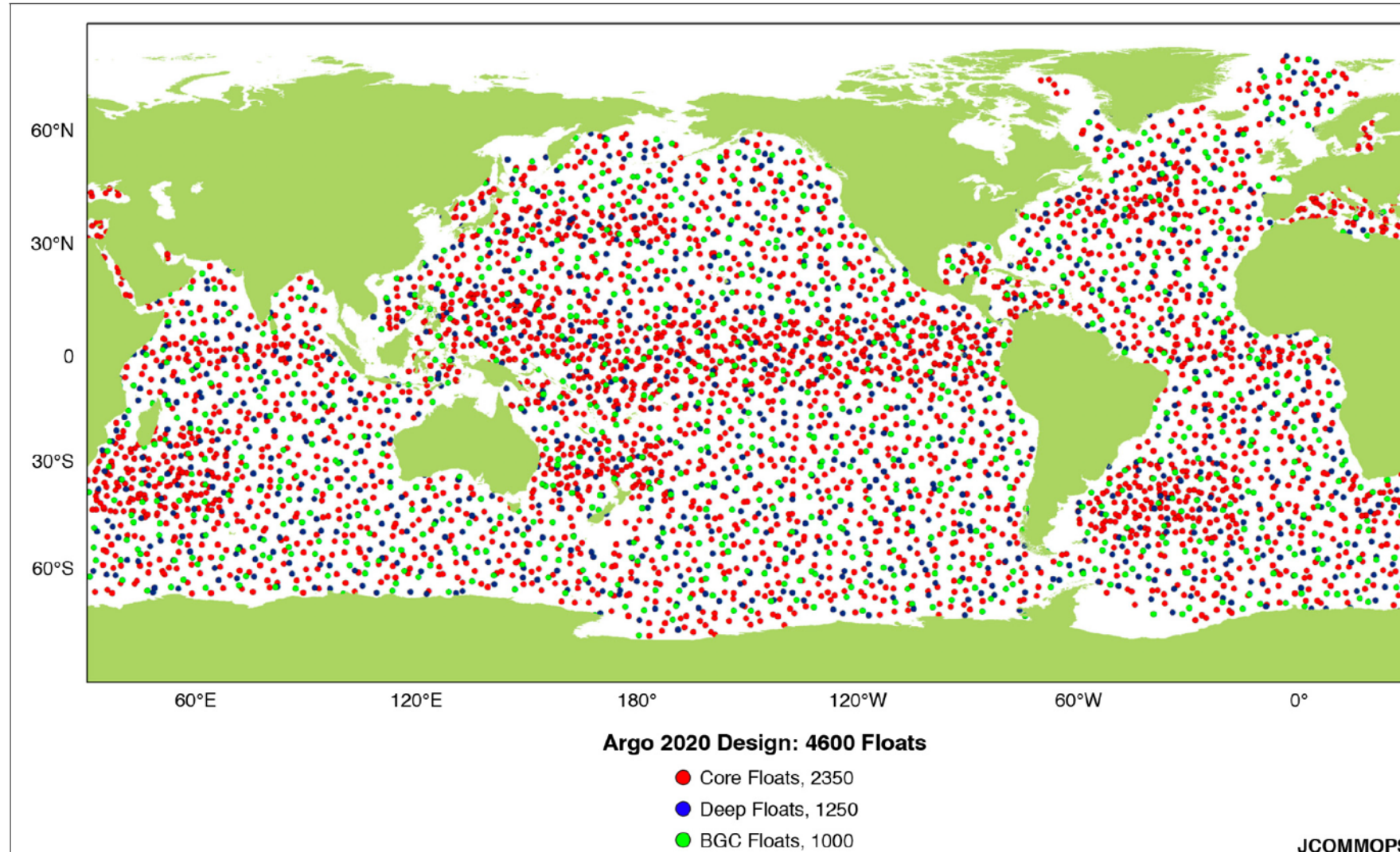

How to accommodate BGC process studies while complying with Argo rules

- Some essential biogeochemical processes can sometimes not be tackled with sufficient detail by Argo standard sampling rule
 - Dynamic of the blooms
 - Export and processes in the mesopelagic
- Their study and quantification require
 - to adapt vertical and/or temporal resolution
 - To implement new sensors
- In the mean time, we need to comply with the Argo standard mission. Basically a float should live at least 5 years (4 years was in the implementation plan) with 6 variables
- We need to have float with extend life-time

Need to develop a better knowledge of the power consumption of the various float's actions

- **Standard BGC-Argo PROVOR 6 core variables : 181 profiles, 5 y**
- b_{bp} and Chla at metric resolution: 207 profiles, 4.7 y
- + UVP (no transmissiometer): 180 profiles, 4.2 y
- **Standard but one cycle to 2000 m every 3 (other @ 1000) : 213 profiles, 5.8 y**
- + UVP (no transmissiometer) 180 profiles, 4.9 y
- b_{bp} and Chla at metric resolution 207 profiles, 5.7 y

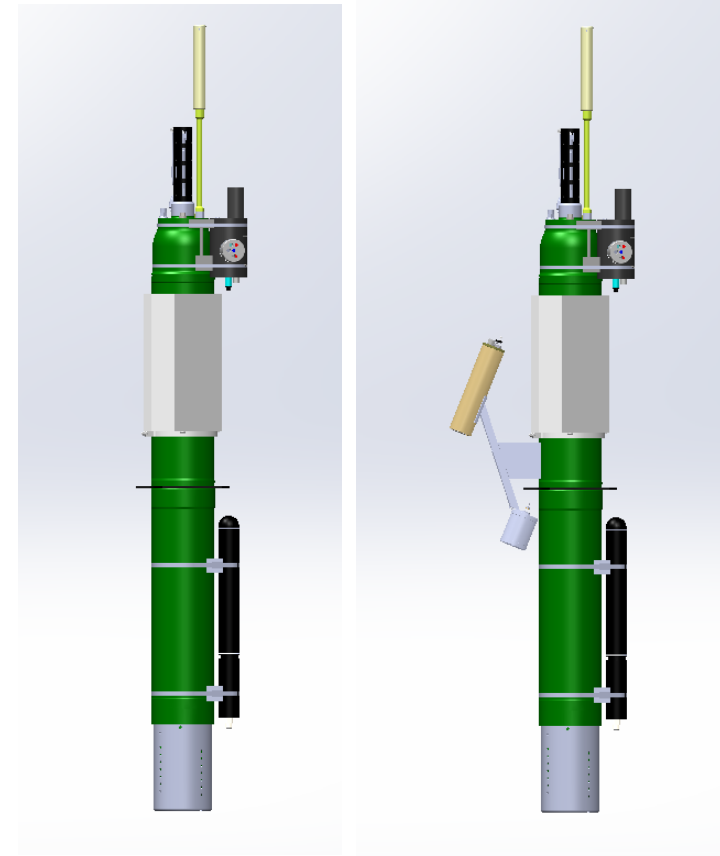

Need to develop a better knowledge of the power consumption of the various float's actions: some

- **Standard BGC-Argo PROVOR 6 core variables**
: 181 profiles, 5 y / 271 profiles, 7.5 y
- b_{bp} and Chla at metric resolution:
171 profiles, 4.7 y / 256 profiles, 7 y
- + UVP (no transmissiometer):
152 profiles, 4.2 y / 228 profiles, 6.3 y
- **Standard but one cycle to 2000 m every 3**
(other @ 1000) : 213 profiles, 5.8 y / 320
profiles, 8.7 y
- b_{bp} and Chla at metric resolution
207 profiles, 5.7 y / 310 profiles, 8.5 y
- + UVP (no transmissiometer)
180 profiles, 4.9 y / 270 profiles, 7.3 y

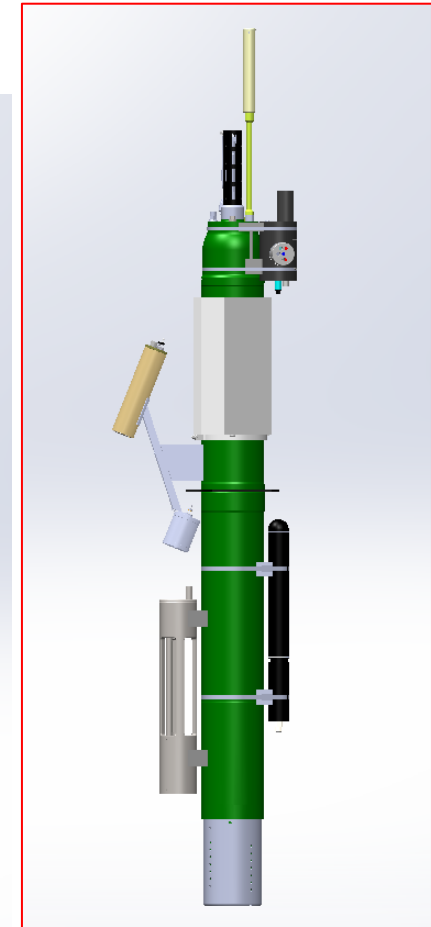
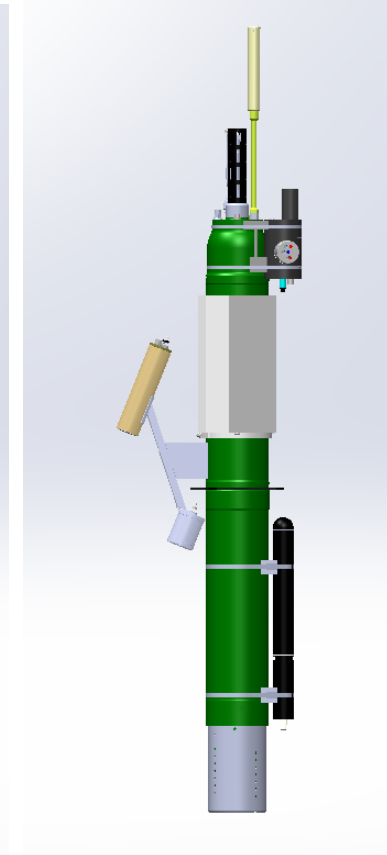
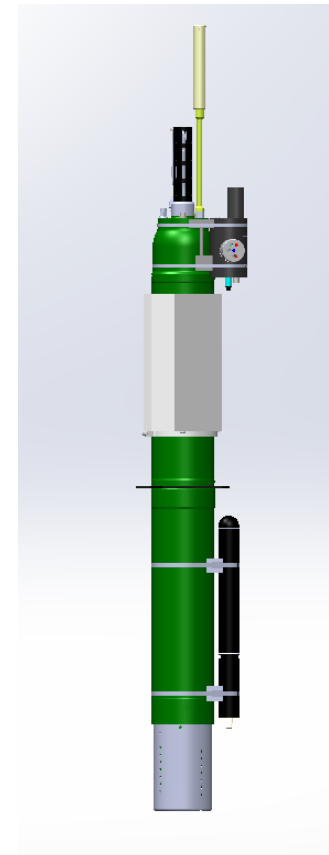

**Hull + 20 cm &
60% more batteries**

Some final messages

- The technology is ready for developing comprehensive time series of processes driving Biological Carbon pumps and for addressing the biomass mesopelagic animals (resources).
- We are ready to implement, in complement to “background” BGC-Argo (6 variables, 10-day resolution), robotic process studies with enhanced BGC-Argo payload (imaging, acoustic, OST...) and adaptative sampling.
- Many the properties inferred from such robotic observation are done trough the use of (optical) proxies. => Calibration cruises are essential.

Thanks for your attention !

Balancing between Argo monitoring rules and the need for BGC-Argo process studies at specific scales

- If we want to attract new players into BGC-Argo who will become our advocates we need to find ways to satisfy them
- Increased temporal resolution.
 - Catching biological event (blooms, export, diurnal migration) with specific time scales
 - Cyclone : coordination of fltas on one place
- Increased temporal resolution
 - Thin layers, Deep Chlorophyll maxima, raze event of particle linked to export
- New sensors
 - Imaging and size particle for zooplankton / export
 - Active acoustic for zooplankton
- Several options for this
 - The scientist contribute to the additional consumption linked to it's a
 - In the mean time we improve technology for delivering more energy
- Last AST, Dean pushed the community to target float with ~7 years life-time on Argo mode (i.e. 250 profiles)...
- This is even more challenging for BGC-Argo.
 - Additional standard sensors => additional consummations
 - Possible new applications / variables in the future
 - According to